

# AutoCAD 2011: One Step at a Time

## Lesson 8: Editing Your Drawings – Modification Procedures

<b>11R8</b>	<b>Exercises</b>
-------------	------------------

1. Open the *Checkers* drawing in the C:\Steps\Lesson08 folder.
  - 1.1. Using the commands you've learned in this lesson, create the drawing from the objects provided. (Be sure to use different layers and colors to mark the different sides.)

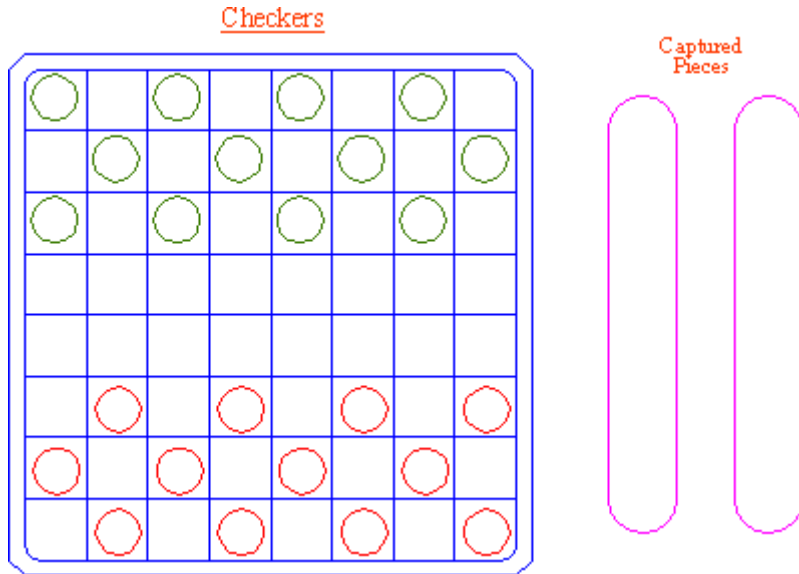

2. Using the *MyGrid3* template you created in Lesson 1 (or the *Grid3* template in the Lesson01 folder), create the drawing below. Reset the grid to 1/4" and the snap accordingly. Use the same layers you used in Exercise #3 of Lesson 6. Don't draw the dimensions.

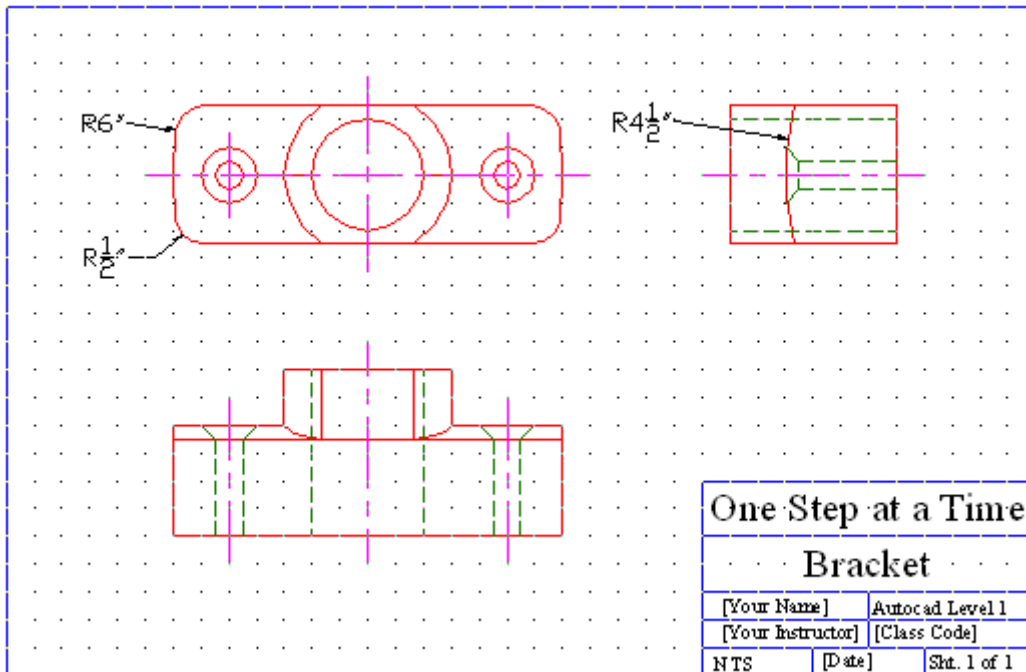

3. Using the following setup, create the *log cabin* drawing.

3.1. Lower left limits: 0,0

3.2. Upper right limits: 36,24

3.3. Grid & Snap: [as needed]

3.4. Layers: (see the table)

The details are shown in the following figures.

<u>Layer Name</u>	<u>Color</u>	<u>Linetype</u>
0	black	Continuous
Curtains	212	Continuous
Dim	blue	Continuous
Gable	30	Continuous
Log	23	Continuous
Roof	green	Continuous
Steel	62	Continuous
Text	42	Continuous

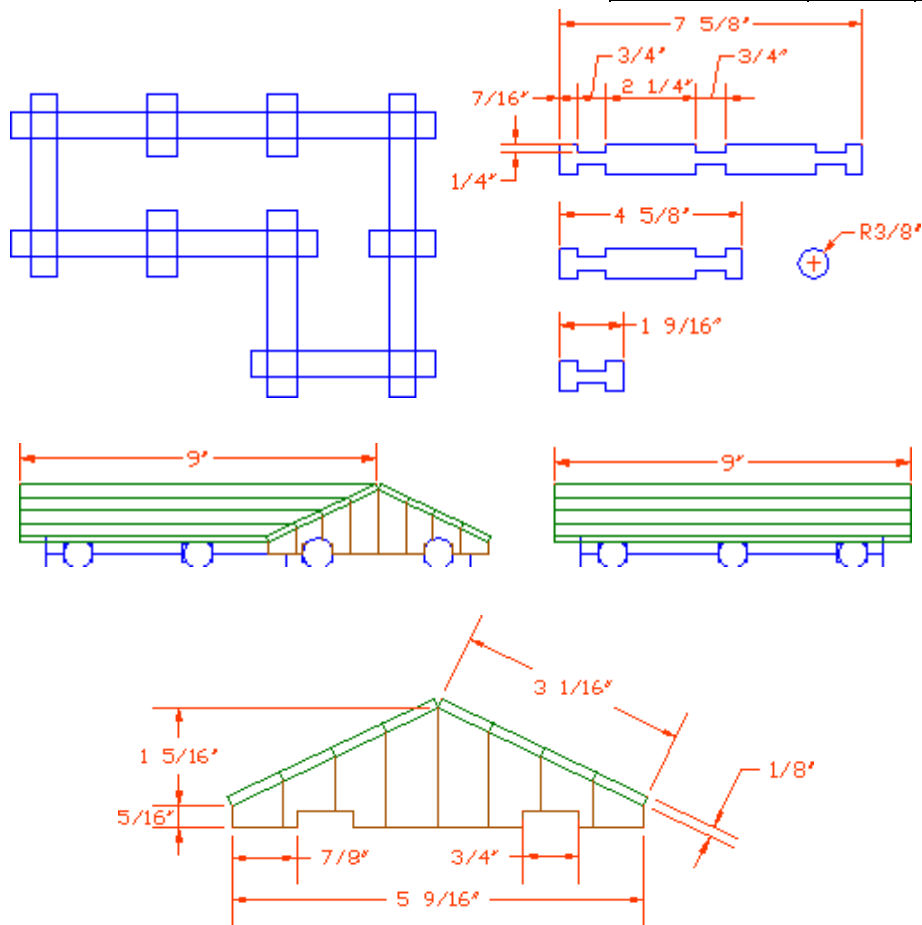

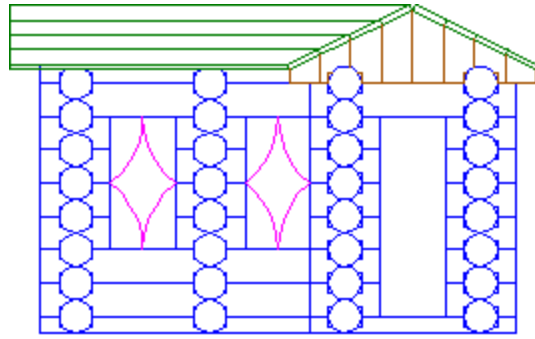

Front

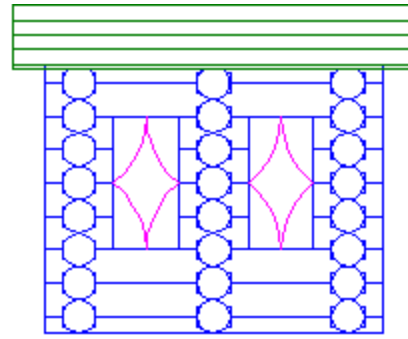

Right Side

4. Using what you've learned, create these drawings. Create separate layers for the different objects & linetypes, and for the text (where applicable).

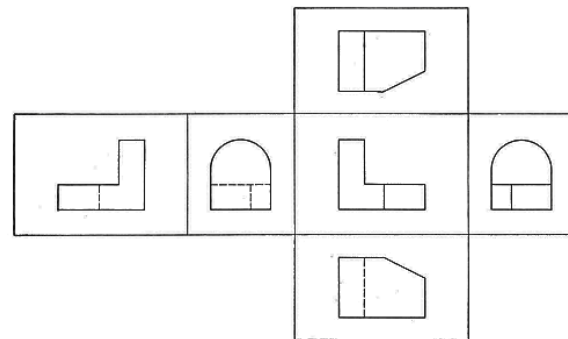
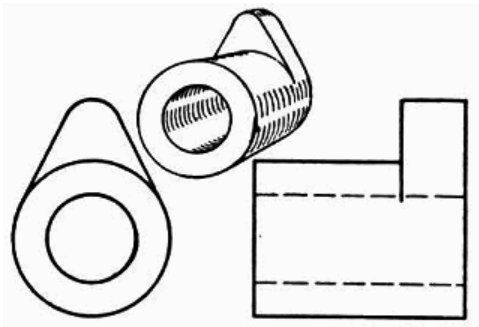
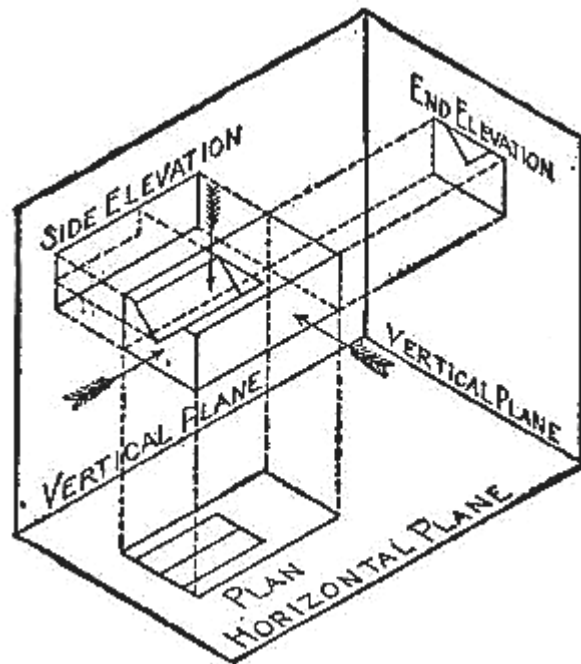

- Now create the drawings in the window and door below. Be sure to set up the drawing limits, layers, and whatever grid and snap you think will be useful. Each drawing should be set up for plotting onto an 8½"x11" sheet of paper, and should be drawn to scale when dimensions are provided. (Don't draw the dimensions.)

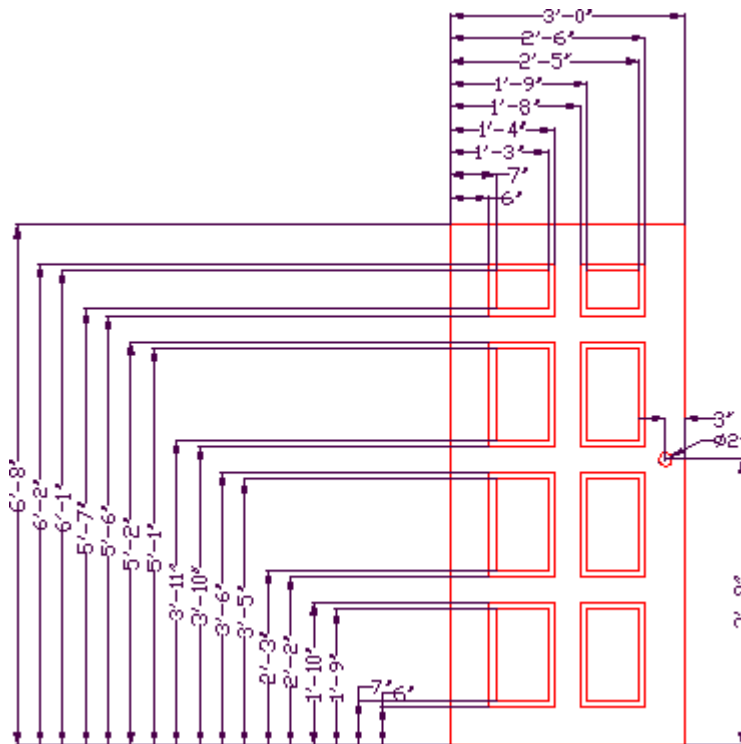
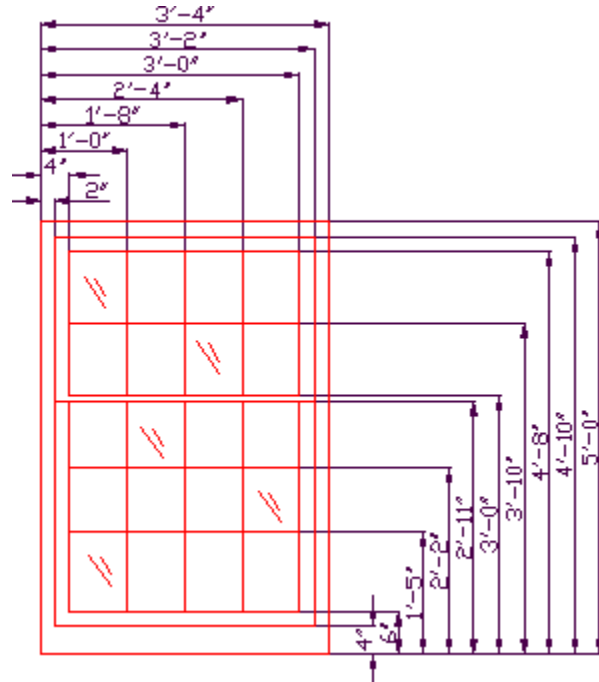

6. Now see what you can do with the remaining drawings.

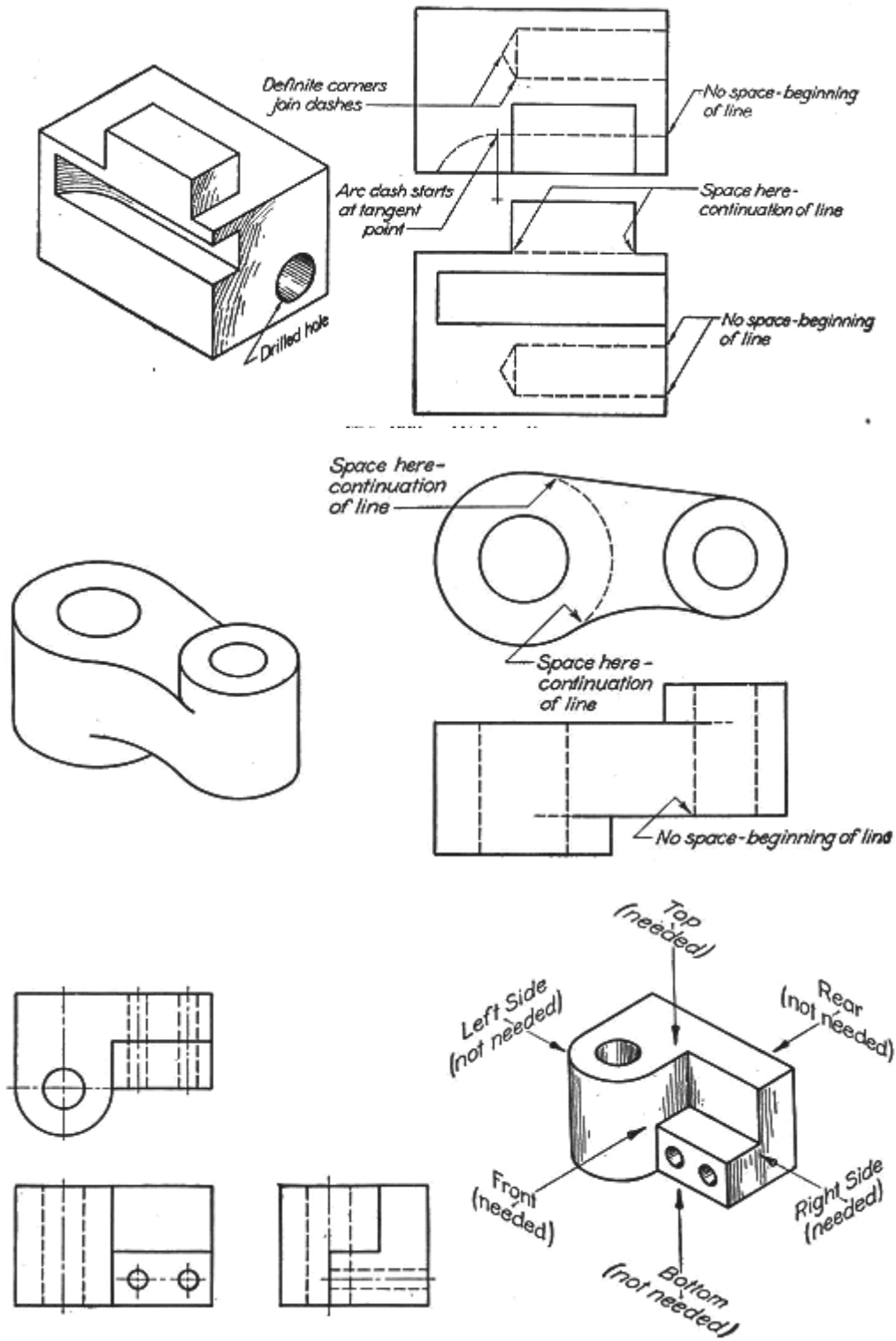

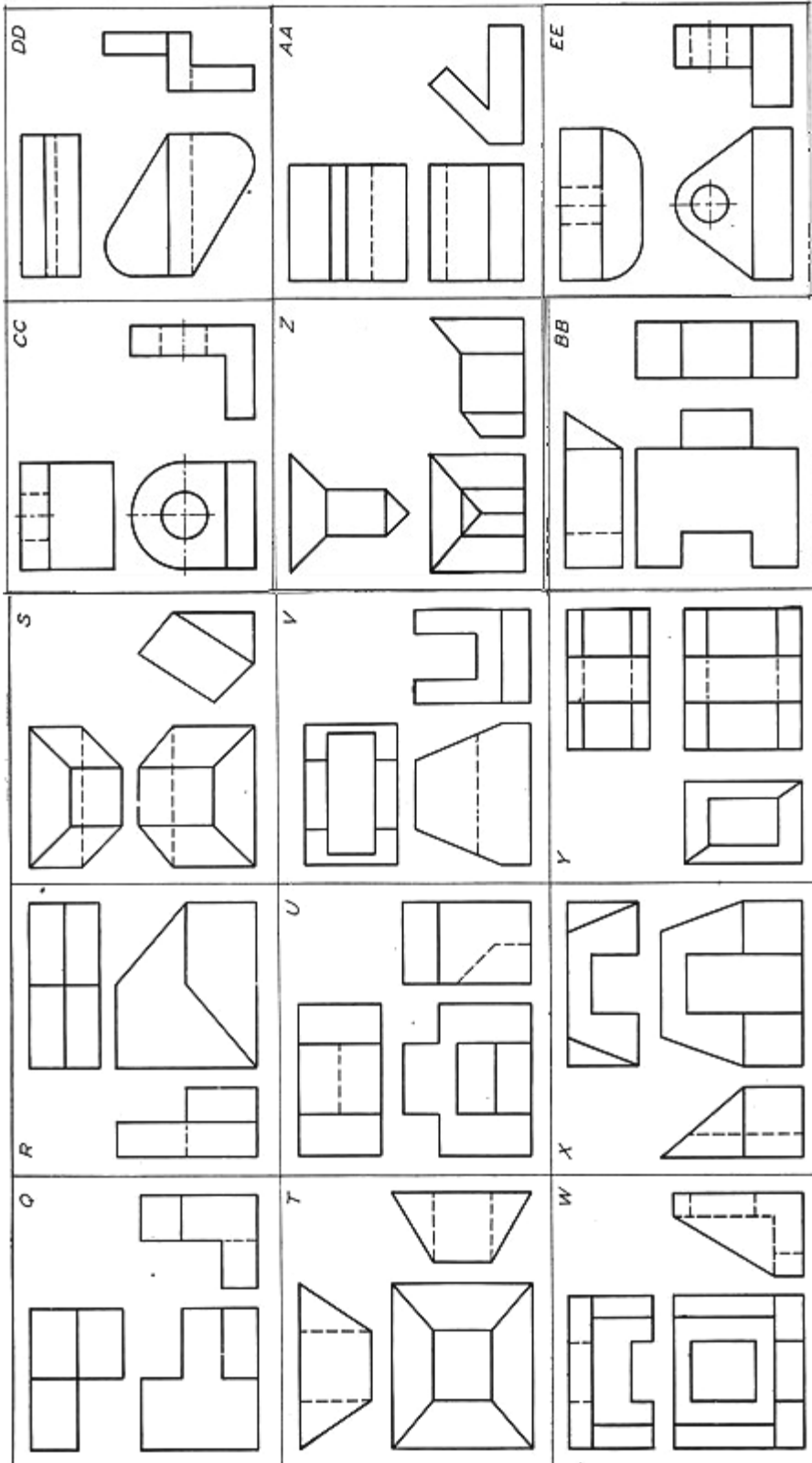

Please write your answers on a separate sheet of paper.

1. AutoCAD designed the \_\_\_\_\_ command to remove parts of lines or circles.
2. \_\_\_\_\_ are usually lines or circles to which you want to trim.
3. (T or F) In the Trim command, the cutting edge must touch the object to be trimmed.
4. Set the \_\_\_\_\_ to "extend" the plane of the cutting edge in the Trim command.
5. Use the \_\_\_\_\_ command to handle a problem where a line is short of where it should reach.

The Trim command prompts you for a (6) edge while the Extend command prompts you for a (7) edge.

- 6.
- 7.
8. To remove part of a line, circle or arc without using a cutting edge, use the \_\_\_\_\_ command.
9. To break an object into two pieces without removing one of the pieces, type \_\_\_\_\_ at the Enter second point: prompt of the Break command.
10. Use the \_\_\_\_\_ command to create rounded or squared corners.
11. To remove the extra portions of line or circles during the Fillet or Chamfer command, set the \_\_\_\_\_ to One.
12. To angle a corner, use the (Chamfer, Mitre) command.

Name the two methods of drawing a chamfer.

- 13.
- 14.

To use the displacement option to move an entity three units along the X-axis and 0 units along the Y-axis, type (15) at the Base point or [Displacement] prompt, and (16) at the Second point prompt.

- 15.
- 16.
17. (T or F) You can only move one object at a time, but you can copy several objects at once.
18. To move and rotate an object at one time, use the \_\_\_\_\_ command.
19. (T or F) You can resize an object with the Align command.
20. (T or F) AutoCAD automatically allows you to make multiple copies of objects with the Copy command.



Identify these buttons:



30. To copy an object from one drawing to another, use the (Windows, AutoCAD) copy command.
31. To move an object from one drawing to another, use the Windows (Cut, Paste, Cut & Paste) command(s).
32. (T or F) You can only enter the Trim command by selecting the Trim button on the Modify toolbar.
33. (T or F) You cannot extend an object from within the Trim command.
34. (T or F) A line or arc may be used as a cutting edge.
35. (T or F) The Extend command and the Trim command share the Edgemode system variable.
36. (T or F) The boundary edge referred to by the Extend command is the object that you wish to extend.
37. (T or F) Holding down the SHIFT key when at the Select object to extend prompt will cause the selected object to trim rather than extend.
38. (T or F) The drafter may pick the Change button on the Modify control panel to call the Change command.
39. (T or F) The F option of the Break command enables the user to identify the first and last endpoints of a line to precisely define the area to break.
40. Should you want to create a single break, you should
  - a. try to pick the second point as closely as possible to the first
  - b. use OSNAPs to select the same point twice
  - c. use the @ symbol when prompted for the second point
41. (T or F) The Break command can only be entered at the command line.
42. (T or F) The Fillet command can not make square corners since a fillet, by definition, is round.
43. (T or F) It is difficult to change the default radius of the fillet from .5.
44. (T or F) For all the corners of a polyline to be filleted at the same time, use the Polyline option of the Fillet command.
45. (T or F) Excess parts of a line can be trimmed when the line is filleted.
46. (T or F) The Chamfer command will give the user a rounded corner rather than a mitered corner.
47. (T or F) The Chamfer command measures a user-defined distance from the corner of two objects putting a line between the two points.

48. (T or F) When using the Distance method of the Chamfer command, AutoCAD prompts for two distances and then for an angle.
49. (T or F) When using the Angle method of the Chamfer command, AutoCAD prompts for one distance and then for an angle.
50. (T or F) The Move command has only two options – Base Point and Displacement.
51. (T or F) The displacement method of the Move and Copy commands requires that you key in the number of units you want to move along the X and Y axes.
52. (T or F) The Align command not only moves objects, but aligns them with other objects.
53. (T or F) The Align command always requires a third source/destination point.
54. (T or F) The hotkeys Co or Cp are acceptable ways to call the Copy command.
55. (T or F) The Copy command must be entered each time a copy of an object is needed.
56. Three Paste options are presented on the cursor menu
- Paste (pasteclip)
  - Paste as Block (pasteblock)
  - Paste to Original Coordinates (pasteorig)
  - Paste to Base Coordinates (pastebase)
57. (T or F) The Cut option on the cursor menu (the CutClip command) is the first step of the Windows method for moving objects.
58. (T or F) Use the MDE command to move and copy objects between drawings.
- List the three commands that can make identical copies of AutoCAD objects.
- 59.
- 60.
- 61.
62. Which command would you use to create parallel or concentric circles?
63. Using the distance option of the Offset command enables you to specify the (linear, perpendicular) distance between the original object and its copy.
64. The \_\_\_\_\_ command will make a reversed copy of the original objects selected.
65. (T or F) The Offset command contains an option that allows you to place copies on the current layer.
66. (T or F) Offset can only copy a single object at a time.
67. The \_\_\_\_\_ option of the Array command will place objects in a circle or arc.
- By default, AutoCAD will mirror all objects except (68) unless the (69) sysvar is set to one.
- 68.
- 69.

Identify these buttons and the hotkeys that are associated with their commands.

<b>Button</b>			
<b>Command</b>	70.	72.	74.
<b>Hotkey</b>	71.	73.	75.

76. The Through option of the Offset command relates to
- completing the Offset command
  - completing work in the current drawing session only
  - a point through which a copy of the offset object will pass
77. (T or F) When the user has specified a distance in response to the initial Offset prompt, he still must pick a direction for the offset.
78. (T or F) Offset is a repetitive command. That is, it continues until the user hits enter to complete it.
79. (T or F) The Array command will not only give the user many copies, but will place the copies in ranks or circles.
80. (T or F) The Angle to fill of the defining arc or circle of a Polar Array is always counter-clockwise.
81. (T or F) Use the PolArray command for Polar Arrays and the RecArray command for rectangular arrays.
82. (T or F) In the Array command dialog box, “Rotate objects as copied” means that the top part of any object will remain on top for each of the copies.
83. (T or F) The Polar option of the Array command requires that the user identify the distance between rows and columns.

## Answers

- |                    |                 |                   |
|--------------------|-----------------|-------------------|
| 1. Trim            | 29. Trim        | 57. T             |
| 2. Cutting Edges   | 30. Windows     | 58. F             |
| 3. F               | 31. Cut & Paste | 59. Copy          |
| 4. Edgemode        | 32. F           | 60. Offset        |
| 5. Extend          | 33. F           | 61. Array         |
| 6. Cutting         | 34. T           | 62. Offset        |
| 7. Boundary        | 35. T           | 63. Perpendicular |
| 8. Break           | 36. F           | 64. Mirror        |
| 9. @               | 37. T           | 65. T             |
| 10. Fillet         | 38. F           | 66. T             |
| 11. Trimmode       | 39. T           | 67. Polar         |
| 12. Chamfer        | 40. c           | 68. Text          |
| 13. Distance       | 41. F           | 69. Mirrtext      |
| 14. Angle          | 42. F           | 70. Mirror        |
| 15. 3,0            | 43. F           | 71. Mi            |
| 16. Hit Enter      | 44. T           | 72. Offset        |
| 17. F              | 45. T           | 73. O             |
| 18. Align          | 46. F           | 74. Array         |
| 19. T              | 47. T           | 75. Ar            |
| 20. T              | 48. F           | 76. c             |
| 21. Copy           | 49. T           | 77. T             |
| 22. Move           | 50. T           | 78. T             |
| 23. OSNAP Settings | 51. T           | 79. T             |
| 24. Fillet         | 52. T           | 80. F             |
| 25. Chamfer        | 53. F           | 81. F             |
| 26. Break          | 54. T           | 82. F             |
| 27. Ortho toggle   | 55. F           | 83. F             |
| 28. Extend         | 56. a, b, & c   |                   |