

AutoCAD 2010: One Step at a Time

Lesson 11: Some More Cool Tools

10R11	Exercises
--------------	------------------

1. Open *MyRemote* from the C:\Steps\Lesson07 folder (or you can use the *Remote* drawing in the C:\Steps\Lesson11 folder).
 - 1.1. Using the **Solid** and **Donut** commands you learned in this lesson, fill in the buttons as shown.
 - 1.2. Save the drawing as *MyOtherRemote* in the C:\Steps\Lesson11 folder.

2. Setup a new drawing with the following parameters:
 - 2.1. Limits: [use default limits]
 - 2.2. Grid: .25
 - 2.3. Snap: as needed
 - 2.4. Units: architectural
 - 2.5. Text Height: .125
 - 2.6. The layers below.
 - 2.7. Create the drawing (bottom right).
 - 2.8. Save the drawing as *MyControlPanel* in the C:\Steps\Lesson11 folder.

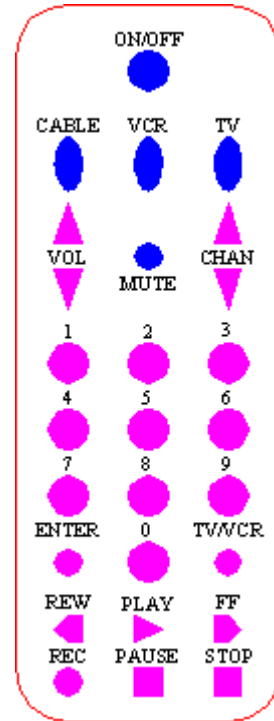

NAME	COLOR	LINE TYPE
0	black	Cont.
But-A	blue	Cont.
But-B	green	Cont.
Frame	red	Cont.
Infrared	212	Cont.
Lights	32	Cont.
Switch	84	Cont.
Text	12	Cont.
Vent	black	Cont.

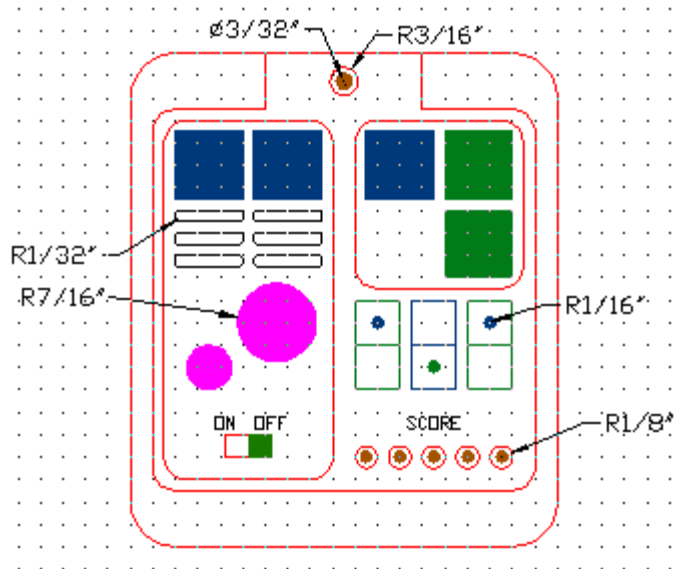

3. This exercise can be a lot of fun. Follow these parameters when setting it up:

3.1. Lower left limits: 0,0

3.2. Upper right limits: 11'6,7'

3.3. Grid: 6"

3.4. Snap: as needed

3.5. The wagon is a 30"x4" solid and the wheels are donuts with outer diameters of 6" and inner diameters of 4"; the hub is a donut with an outer diameter of 2".

3.6. The pickets are 5½" wide and have a ½" gap between them.

3.7. The hedge is made up of arcs.

3.8. Use the layers at right.

3.9. Save the drawing as *MyYard* in the C:\Steps\Lesson11 folder.

NAME	COLOR	LINETYPE
0	black	Continuous
Fence	212	Continuous
Hedge	green	Continuous
Steel	blue	Continuous
Text	12	Continuous
Wagon	red	Continuous
Wheel	30	Continuous

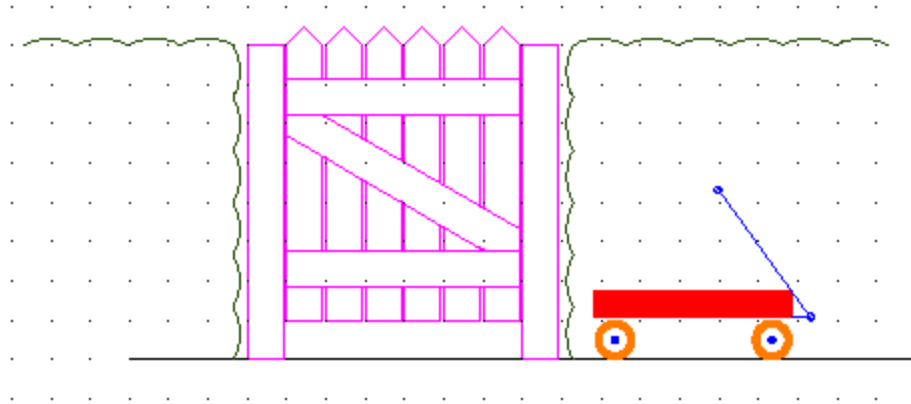

4. Now create the next two drawings. Start with a grid on the Gable Vent drawing of 3" and limits of 0,0 and 15',10'. The grid on the Layout for Radiant Electrical Heating System (next page) is 6" and the limits are 0,0 and 16'6,15'. Set up your own layers for each drawing.

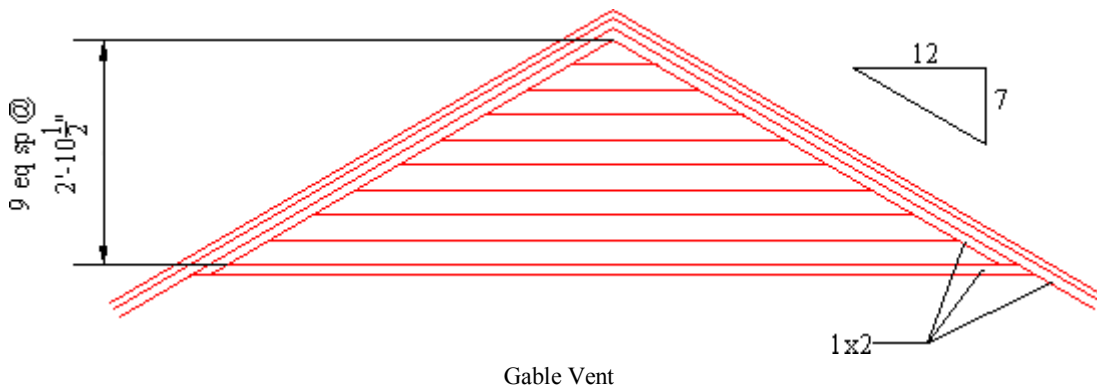

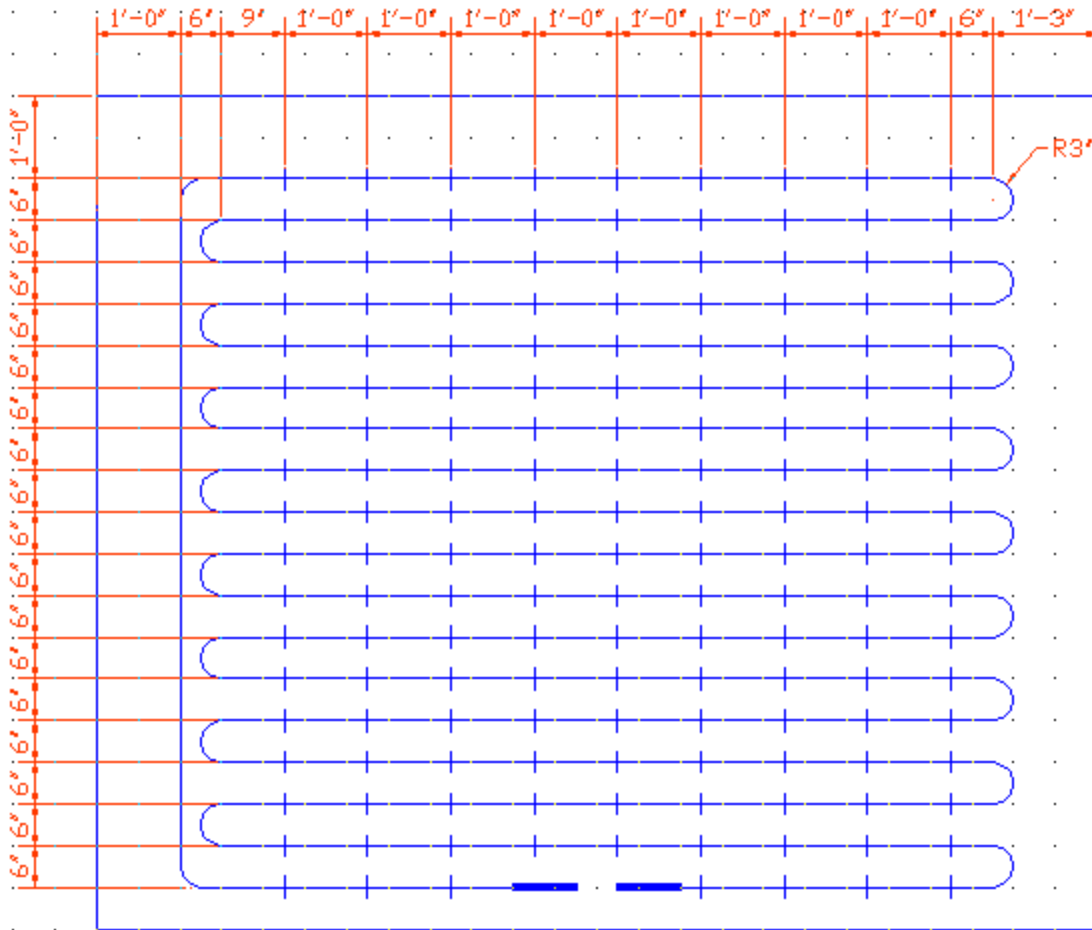

Layout for Radiant Electrical Heating System

5. Create the schematic.
 - a. Use default limits.
 - b. The Grid is 0.5.
 - c. Polylines are 1/16".
 - d. Use solids rather than polylines in the upper box.
 - e. Donuts are 3/16" diameter.

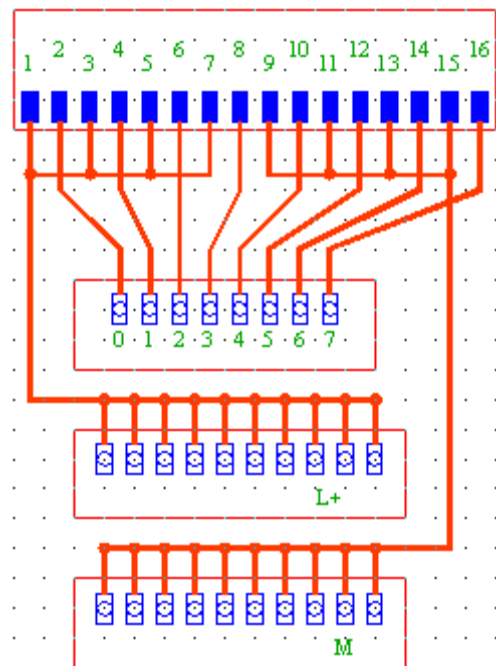

6. Using what you've learned, create the electrical board below. Be sure to use appropriate layers. The grid is 1/2" and the limits are the default for a new drawing. The polylines are 1/16" wide and the outer diameter of the donuts is 3/16".

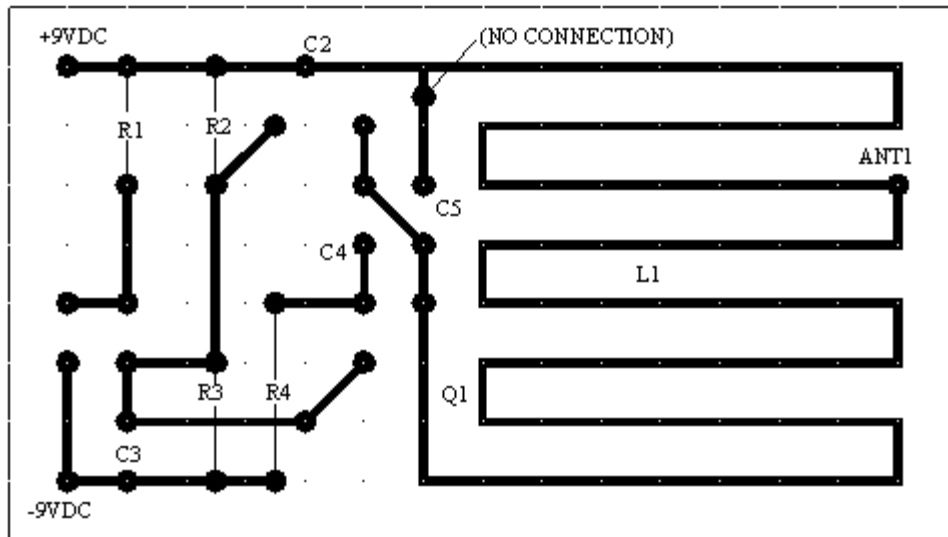

7. Create the schematic below.
- f. The limits are 17" x 11".
 - g. The Grid is 0.5.
 - h. Polylines are 1/16".
 - i. Use solids rather than polylines in the lower box.
 - j. Donuts are 3/16" diameter.

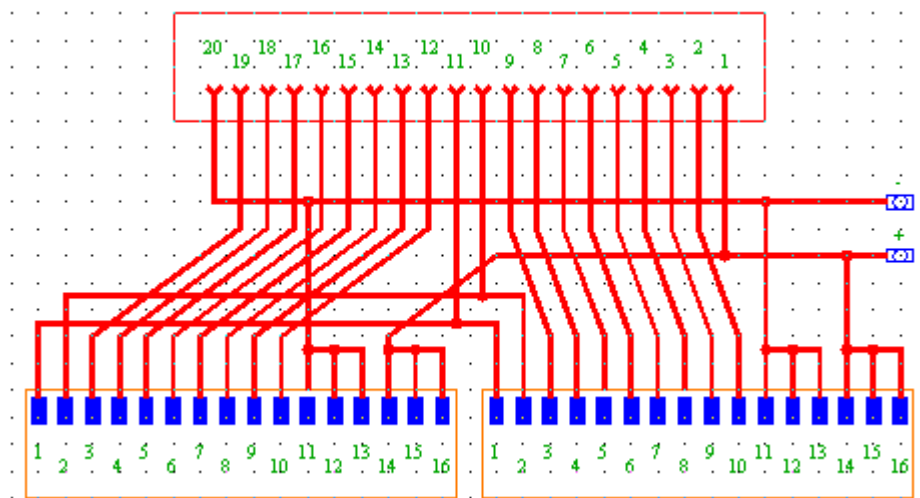

Schematic #2

Please answer these questions on a separate sheet of paper.

1. What is the name of the discipline that manufactures objects directly from CAD drawings? _____
2. _____ places nodes at user-set distances along an object.
3. _____ places equally spaced nodes along an object.
4. A _____ is an object that occupies a single point.
5. The user can place nodes anywhere in a drawing using the _____ command.
6. To hide nodes without erasing them or freezing their layer, set the point style to _____.
7. You must _____ the drawing to see any changes to the style of nodes.
8. What is the sysvar that stores the current point type? _____

What are the two commands that can show a solid surface in the 2-dimensional world?

- 9.
- 10.

In order to save ink and regeneration time when using solids or donuts, set the (11) system variable to (12).

- 11.
- 12.
13. When selecting multiple objects, the user may type _____ at the Select objects prompt to line out each side of a window.
14. When selecting multiple objects, the user may type _____ at the Select objects prompt to line out each side of a crossing window.
15. A _____ acts like a single-line crossing window.
16. _____ allows the user to remove objects from a selection set.
17. _____ provides a dialog box used to filter objects in a selection set.
18. (T or F) Both commands, Divide and Measure, place a node at spaced points on a line or circle.
19. (T or F) A block instead of a node may be used to mark spaced points in the Divide command.

20. Which pick would not be needed to access the Divide or Measure command via the Draw panel?
- a. Draw (subpanel)
 - b. Comma
 - c. Divide (or Measure)
21. (T or F) Measuring user-set distances along a line with the Measure command means that all distances except the last will be equal.
22. (T or F) The Divide command places equally spaced nodes along a line.
23. (T or F) The drafter will always be able to see points (or nodes) in a drawing.
24. (T or F) You shouldn't use OSNAPs to place points.
25. (T or F) In the Point option of the Draw pull-down menu, you find Single Point and Multiple Point procedures.
26. (T or F) The only way to access the Point Style dialog box is by typing DDPTYPE at the command prompt.
27. (T or F) AutoCAD's calculator can easily replace a standard handheld calculator.
28. (T or F) You can paste an answer from AutoCAD's calculator directly to the command line in response to a prompt.
29. (T or F) Unfortunately, the Properties palette doesn't yet provide access to the calculator.
30. Use the _____ command to hide areas of a drawing or to provide a blank spot for notes.
31. Use the _____ to create a macro of AutoCAD commands and responses.
32. Pick the _____ button to run the macro.
33. (T or F) Unfortunately, you cannot pause a macro for user input.

Answers

- | | |
|---------------------------------------|---------------------|
| 1. CAM (computer aided manufacturing) | 17. QSelect |
| 2. Divide | 18. T |
| 3. Measure | 19. T |
| 4. Node | 20. b |
| 5. Point | 21. T |
| 6. 1 or blank | 22. T |
| 7. regen | 23. F |
| 8. PDMode | 24. F |
| 9. Solid | 25. T |
| 10. Donut | 26. F |
| 11. Fillmode | 27. T |
| 12. 0 | 28. T |
| 13. wp | 29. F |
| 14. cp | 30. Wipeout |
| 15. Fence | 31. Action Recorder |
| 16. Remove | 32. Play |
| | 33. F |