

AutoCAD 2010: One Step at a Time *Lesson 10: Polylines and Measure Tools*

10R10

Exercises

1. Start a new drawing from scratch. Set the grid to 1/4" and create the image at right. Save the drawing as *MyArrows* in the C:\Steps\Lesson10 folder.

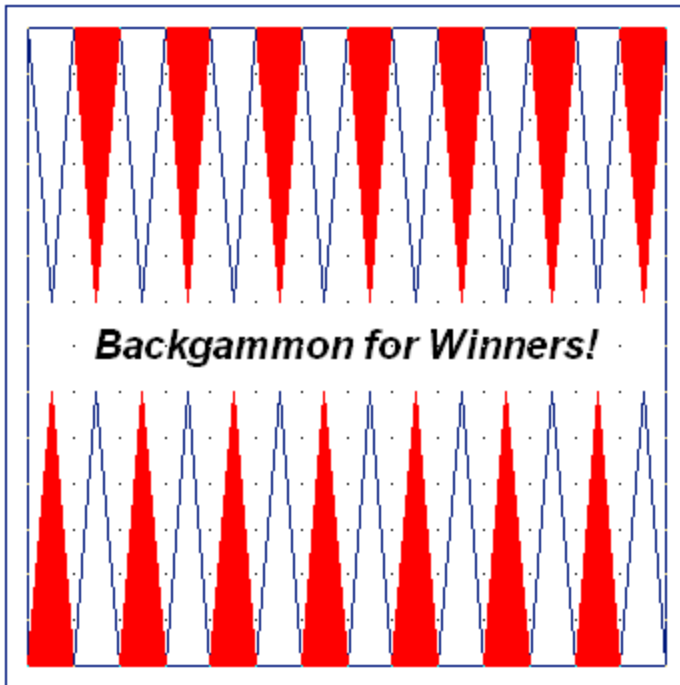

2. Set up a new drawing with the following parameters:
 - 2.1. Lower left limits: 0,0
 - 2.2. Upper right limits: 16,16
 - 2.3. Grid: 1
 - 2.4. Snap: as needed
 - 2.5. Textsize: 5/8
 - 2.6. Text style: Arial font, Bold and Italicized
 - 2.7. Layers: as needed
 - 2.8. Create the backgammon board. Save the drawing as *MyBoard* in the C:\Steps\Lesson10 folder.

3. Create this electrical schematic.

- The grid is 0.5
- Large polylines have a 1/4" width
- Small polylines have a 1/16" width

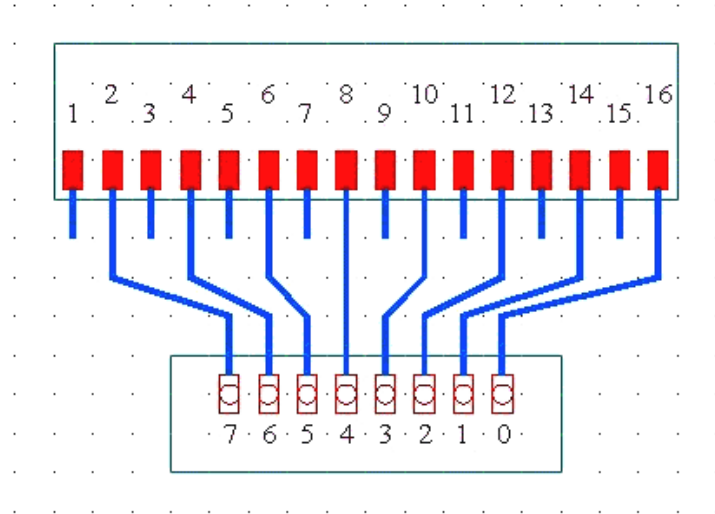

4. The drawing shown is a piping isometric of some pump discharge pipe.

4.1. Set up the drawing as follows:

- 4.1.1. Lower left limits: 0,0; Upper right limits: 17,11
- 4.1.2. Grid: 1/2;
- 4.1.3. Snap: 1/4;
- 4.1.4. Snap Style: Isometric
- 4.1.5. Textsize: 1/4
- 4.1.6. (Suggested) Layers:

NAME	COLOR	LINETYPE
0	black	Continuous
Cl	black	Center
Fitting	212	Continuous
Nozzle	blue	Continuous
Pipe	red	Continuous
Text	blue	Continuous
Valve	212	Continuous

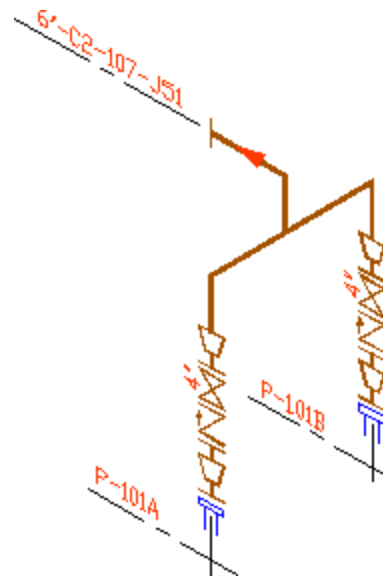

4.2. Details:

- 4.2.1. The width of the pipe is 1/16"
- 4.2.2. The width of the valves and fittings is 1/64"

4.3. Create the drawing. Save the drawing as *MyPipingIso* in the C:\Steps\Lesson10 folder.

5. Use the same settings as in Exercise 3, but make the polyline width $1/32$ for the pipe and 0 for the valves in the drawings below. Use a $1/4$ " grid. Save the drawings as *MyIso1* and *MyIso2* in the C:\Steps\Lesson10 folder.

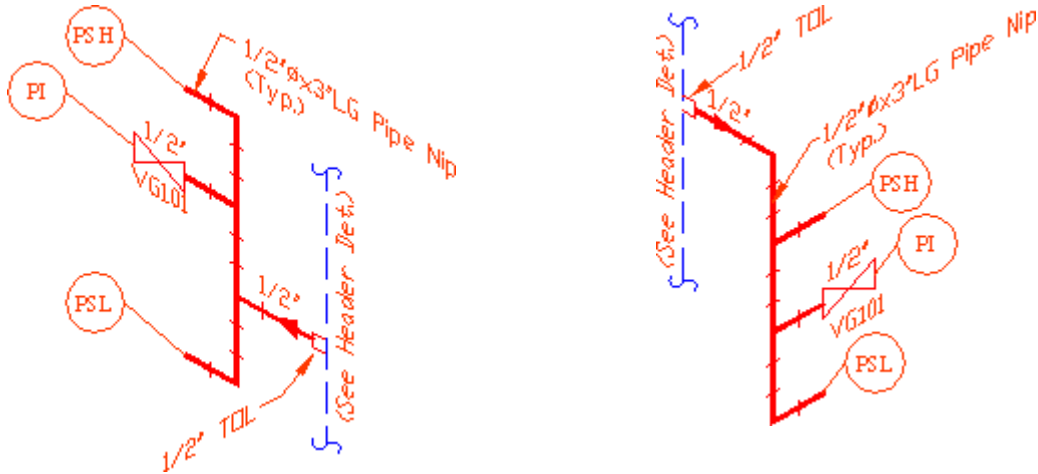

6. Below is one of the cards from my computer.

- 6.1. Draw it using the following setup:

- 6.1.1. Lower left limits: 0,0
- 6.1.2. Upper right limits: 12,9
- 6.1.3. Grid: 1/8
- 6.1.4. Snap: 1/16
- 6.1.5. Layers: (at right)

LAYER NAME	STATE	COLOR	LINETYPE
0	On	black	Continuous
Card	On	212	Continuous
Connection	On	30	Continuous
Mounts	On	blue	Continuous
Slider	On	black	Continuous

- 6.2. Details:

- 6.2.1. The heavy polylines are $1/16$ " wide.
- 6.2.2. The lighter polylines are $1/32$ " wide.

- 6.3. Save the drawing as *MyCard* in the C:\Steps\Lesson10 folder.

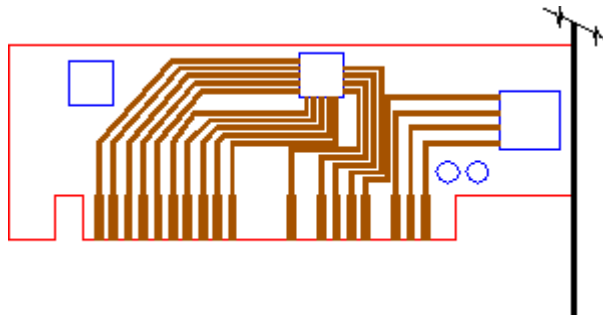

Please write your answers on a separate sheet of paper.

1. Polylines are so named for their ability to be drawn as _____ lines.
2. Capable of containing most of a polyline's information, the _____ is more easily understood and takes up less drawing memory.

Which two polyline options allow you to draw a polyline with width?

- 3.
- 4.
5. When drawing a polyline, what is the first-tier option that repeats until you hit enter to complete the command?
6. The _____ option of the PLine command will present a second-tier of options related to drawing curves.
7. (T or F) AutoCAD isn't case sensitive.
8. (T or F) By manipulating the width option of the PLine command, you can draw arrowheads.

List AutoCAD's five measure options.

- 9.
- 10.
- 11.
- 12.
- 13.

Which two inquiry commands will report the perimeter of a rectangle?

- 14.
15. Which command will you use to identify the coordinate location of the center of an ellipse?
16. What measure option will you use to determine how far it is from one object to another?
17. It's often easier to _____ a simple polyline than it is to edit it.
18. (T or F) It's possible to join a polyline to a line without losing the line's definition in the database.

Which two options of the PEdit command will turn polylines into contour lines?

- 19.
- 20.
21. (T or F) You can create a polyline with different widths at the beginning and ending points.
22. (T or F) You can modify an existing polyline so that the beginning and ending points have different widths.
23. Which option of the PEdit command presents a second-tier of options?
24. Use the _____ command to convert a line to a polyline.

25. Use the _____ command to convert a polyline to a line(s).

Identify the following buttons:

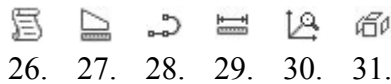

26. 27. 28. 29. 30. 31.
32. (T or F) Each segment of a polyline is considered a separate object.
33. (T or F) There are two types of polyline width available: constant (a polyline which has a constant thickness from beginning to end) or variable (a polyline which starts with one width and ends with another).
34. (T or F) A lightweight polyline, or lwpolyline, takes a bit more memory than a "smart polyline."
35. (T or F) Using the Width option, you can change the width of a polyline.
36. (T or F) A polyline arc, unlike a standard arc, can have varied widths.
37. (T or F) PEdit is the command to edit polylines. With it, the user can change width, combine two lines into one polyline, or use a number of other options to change a polyline's properties.
38. (T or F) The Fit option of the PEdit command will create a smooth straight line.
39. (T or F) The Decurve option of the PEdit command will straighten out any arcs or curves on a polyline.
40. (T or F) You can use the Properties palette to change the linetype of a polyline.
41. (T or F) Use the Ltype Gen option of the PEdit command to have AutoCAD generate a list of the linetypes used to create the polyline.
42. (T or F) You may enter the PEdit command by typing pe, or by double-clicking on the Polyline you want to edit.
43. (T or F) The user can access a second tier of options available through the PEdit command by typing E for the Edit Vertex option of the first tier.
44. (T or F) When the user selects a line rather than a polyline at the PEdit command prompt (Select polyline), AutoCAD will ask if the user wants to turn it into a polyline.
45. To change a polyline into individual lines, you
- use the Line option of the PLine command
 - use the Convert option of the PEdit command
 - use the Explode command
46. (T or F) A Polyline maintains its width after being exploded.
47. (T or F) To join two polylines, they must be touching at endpoints.
48. (T or F) To join two line segments with the Join command, they must be collinear.

Answers

- | | |
|-----------------------|--------------|
| 1. Multi-Segmented | 25. Explode |
| 2. Lwpolyline | 26. List |
| 3. Width | 27. Area |
| 4. Half-Width | 28. Polyline |
| 5. Specify next point | 29. Distance |
| 6. Arc | 30. ID |
| 7. T | 31. Explode |
| 8. T | 32. F |
| 9. Radius | 33. T |
| 10. Distance | 34. F |
| 11. Area | 35. T |
| 12. Angle | 36. T |
| 13. Volume | 37. T |
| 14. Area | 38. F |
| 15. Id | 39. T |
| 16. Dist | 40. T |
| 17. Redraw | 41. F |
| 18. F | 42. T |
| 19. Fit | 43. T |
| 20. SPLine | 44. T |
| 21. T | 45. c |
| 22. T | 46. F |
| 23. Edit Vertex | 47. F |
| 24. PEdit | 48. T |