

AutoCAD 2009: One Step at a Time
Lesson 20: Many as One – Groups and Blocks

09R20

Exercises

1. Using the folder library we began in this lesson, place the doors and windows in the *flr-pln20* file located in the C:\Steps\Lesson20 folder. You'll need to create an additional block to complete the drawing. The details are shown at right. The completed floor plan is shown below (the dimension layer has been frozen for clarity).

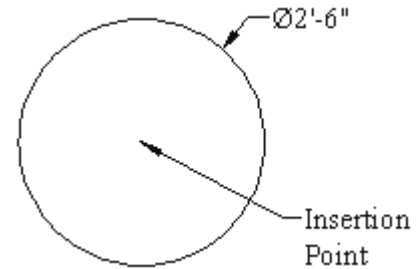

Water Heater

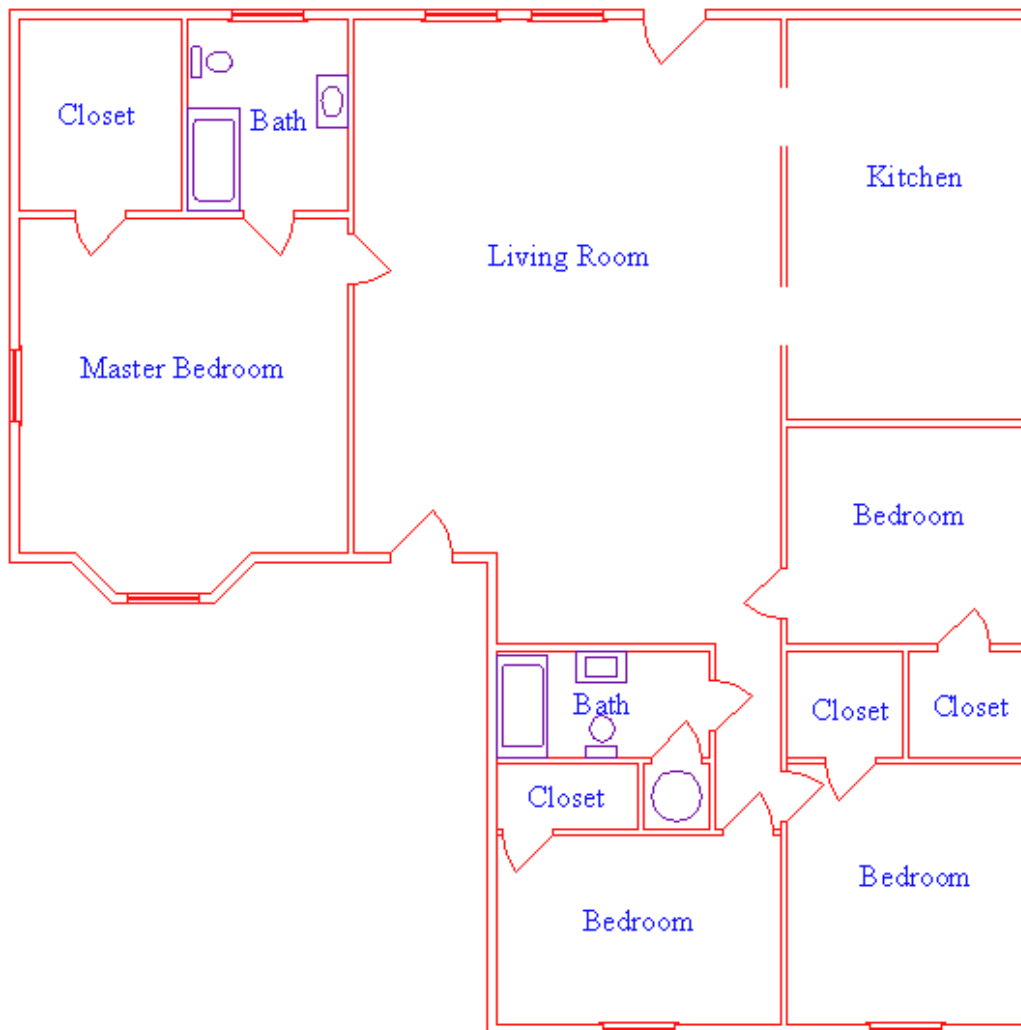

Completed Drawing

2. Start a new drawing from scratch.
 - 2.1. Set the limits for a full scale drawing on an 8½" x 11" sheet of paper.
 - 2.2. Grid: ¼"
 - 2.3. Create the layers indicated (all layers use a continuous linetype).
 - 2.4. Use the Times New Roman or Calibri font. Text sizes are ¼", 0.2", and 1/8."
 - 2.5. Create the blocks shown in the *Legend* (below right). (Remember to create all blocks on layer 0.)
 - 2.6. Create the drawing shown below left (be sure to insert blocks on the appropriate layer). Use a table for the legend. Save it as *MyBridge* in the C:\Steps\Lesson20 folder.

<u>NAME</u>	<u>COLOR</u>
Battery	56
Border	black
Coil	blue
Copperwire	green
Galvanometer	black
Pin	black
Resistor	212
Switch	red
Text	12

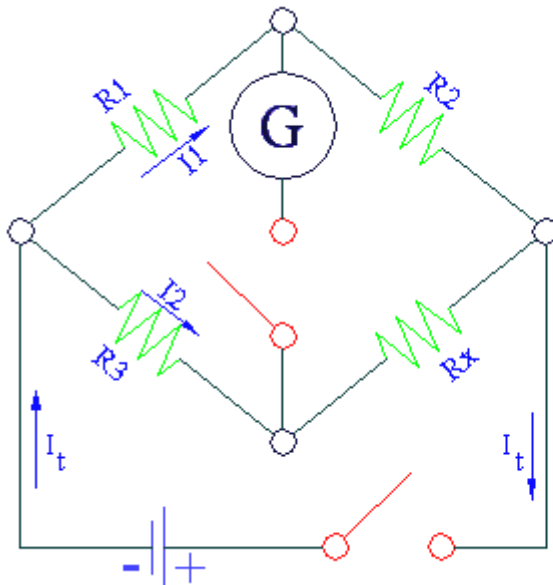

Legend	
	Battery
	Galvanometer
	Long Coil
	Pin
	Resistor
	Short Coil
	Switch

My Bridge

3. On a new drawing, repeat the setup you used for Exercise 2 with the following exceptions:
 - 3.1.1. Add a layer called *Loop* using color 32.
 - 3.1.2. Grid: ½"
 - 3.1.3. Use the standard text style with ¼" and 0.2" text heights.
 - 3.1.4. Use the battery block you created in Exercise 2 and create a block for the wire loop.
- 3.2. Create the *ElectroMagnet Circuitry* drawing at right. Save it as *MyMagnet* in the C:\Steps\Lesson20 folder.

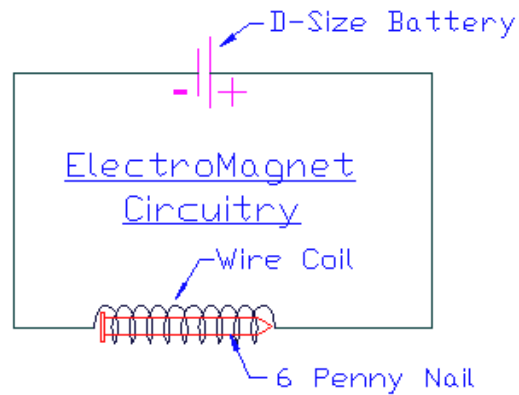

ElectroMagnet Circuitry

4. Using what you've learned, create the following two drawings (next page). Use blocks whenever possible. Be sure to use appropriate layers and complete dimensioning as shown. The details shown below will help. Both drawings should plot on a scale of $3/8"=1'-0"$ on an 11" x 8 1/2" sheet of paper. Use a title block.

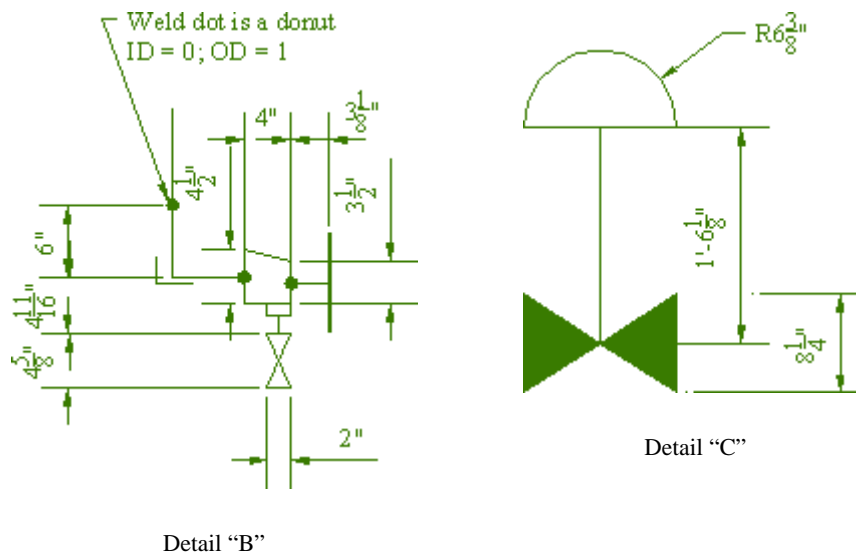
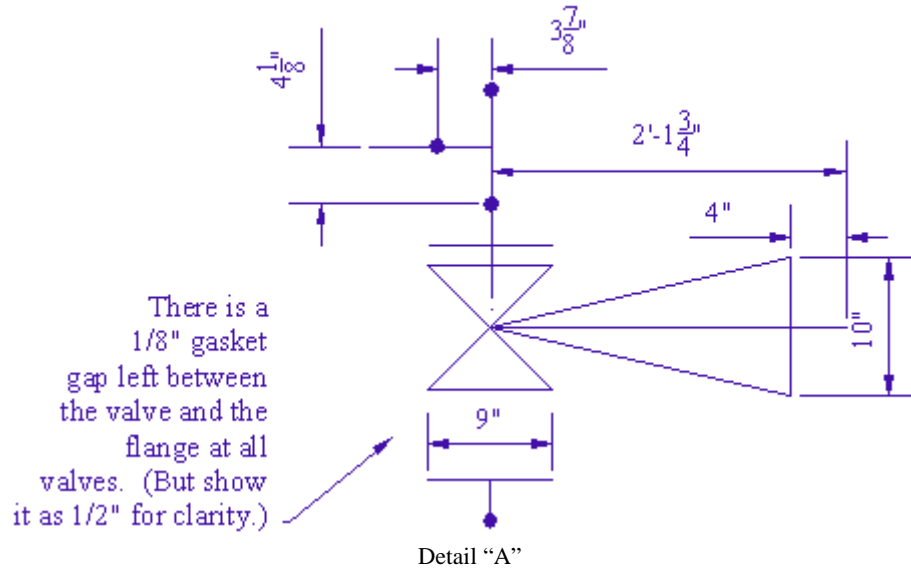

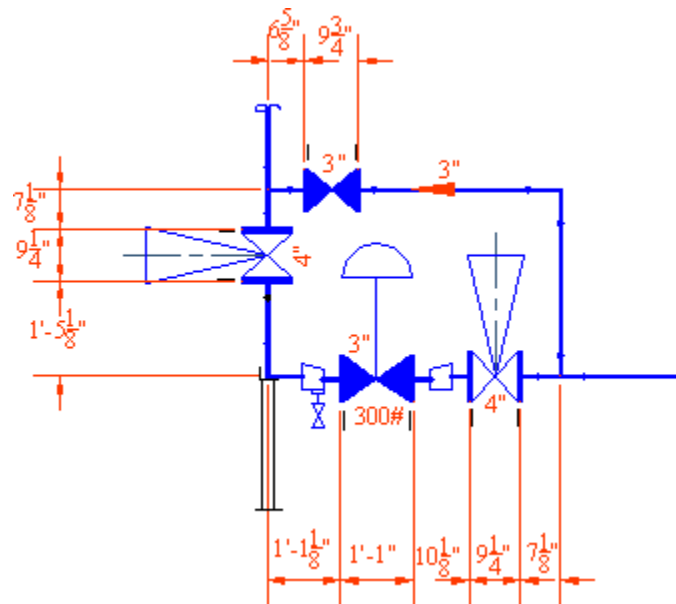
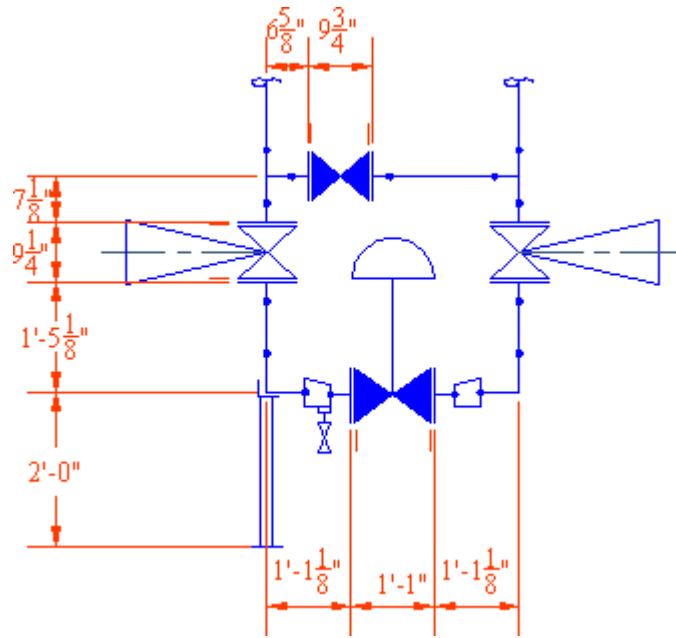

5. Using blocks wherever possible, create the schematic drawing. Again, be sure to use appropriate layers. I used 1/2" grid marks.

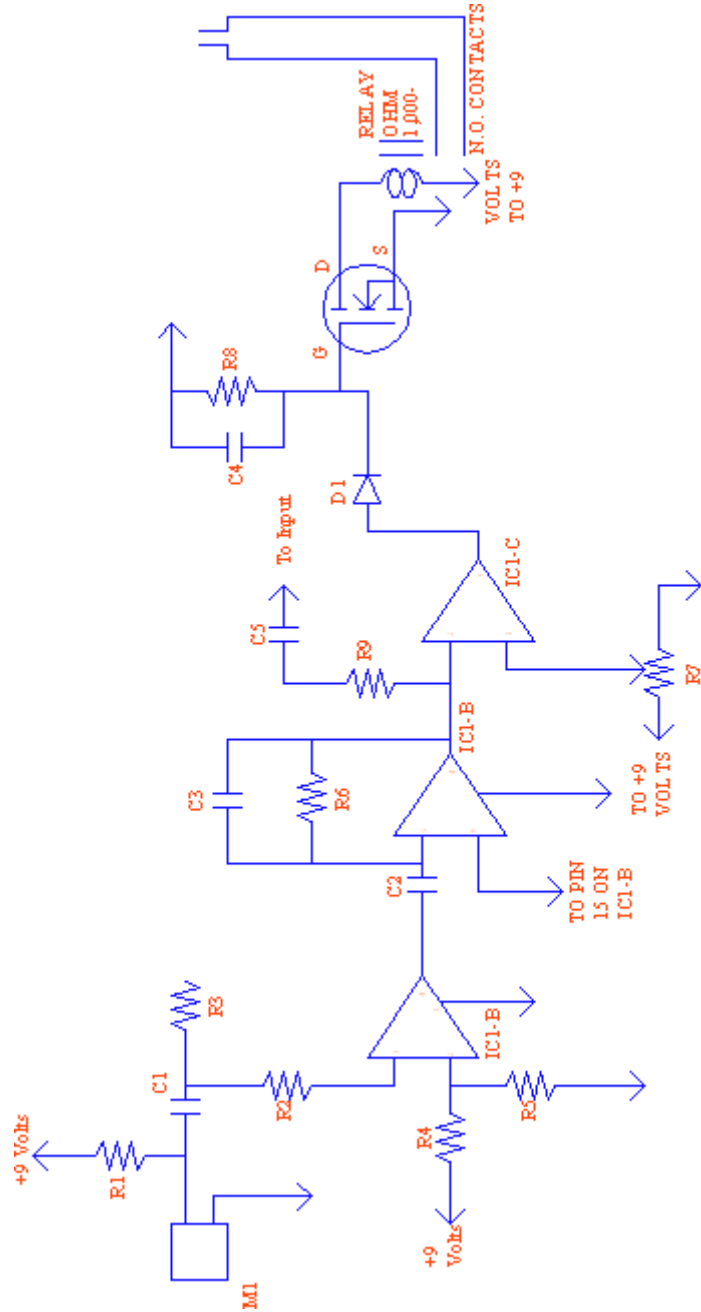

Schematic

6. Using blocks whenever possible, create the two fireplace plans shown below. The grid shown on each is 1".

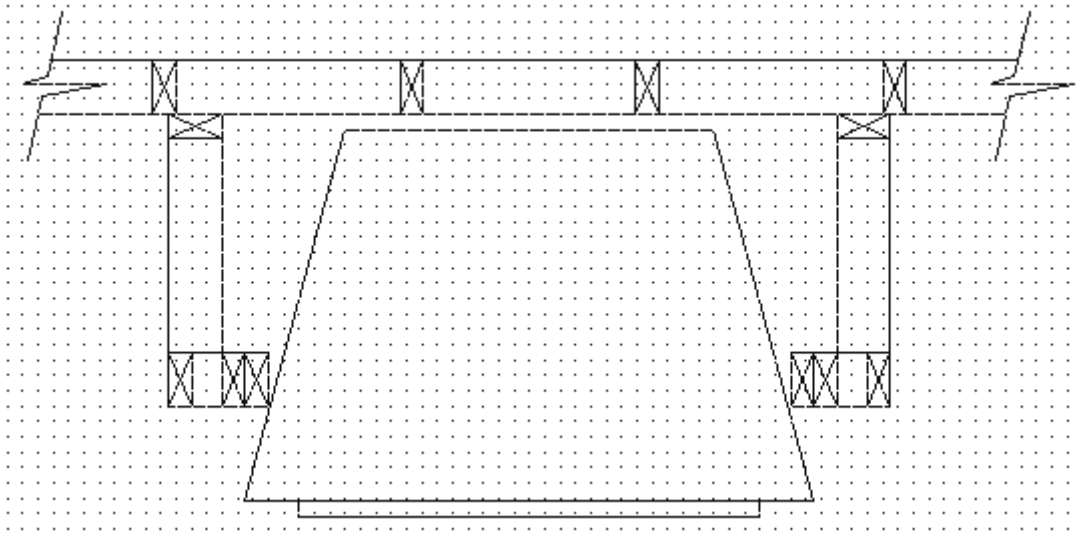

Fireplace Plan #1

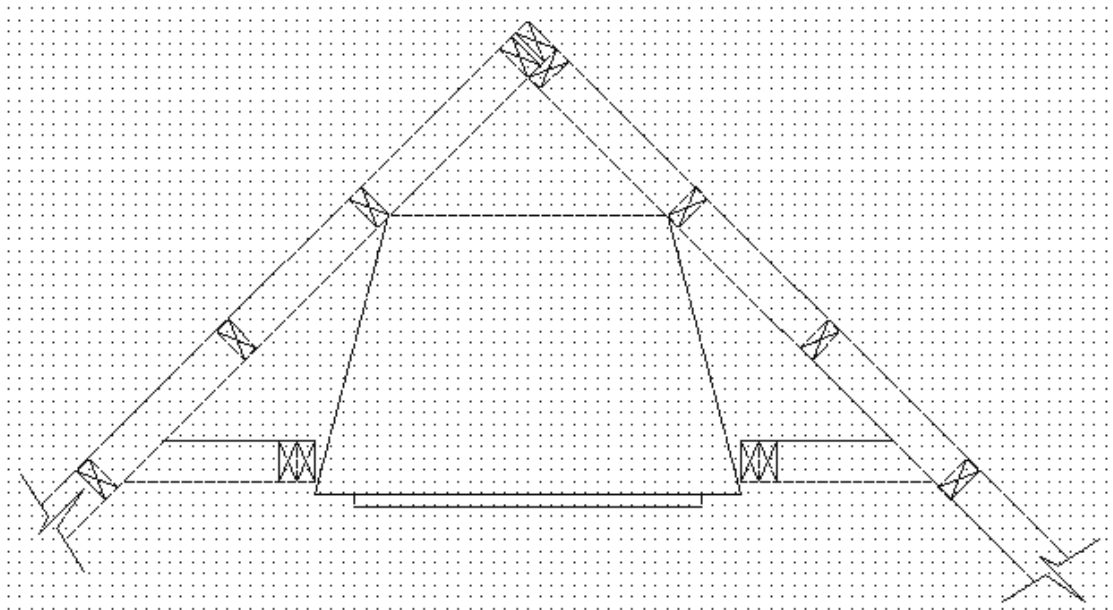

Fireplace Plan #2

Write your answers on a separate sheet of paper.

Two things that are made up of several objects but treated as one are (1) and (2).

- 1.
- 2.
3. Access the Object Grouping dialog box by typing _____ at the command prompt.
4. _____ simply means that a group can be manipulated as a single object.
5. To change one of the objects within a group, change the selectable setting to _____.
6. (T or F) Once a group is defined, the user cannot add or remove objects from it.
7. Pick the _____ button to see which objects are in a group.
8. Use the _____ button to change a temporary group name to something more appropriate.
9. The _____ button will remove the definition of the group from the drawing's database.
10. The _____ button is a toggle for treating a group as a group or suspending the group definition while you modify one or more of the objects within the group.
11. (T or F) Groups can be nested but objects can only belong to one group.
12. (T or F) Group use is limited to a single drawing.
13. (T or F) The group definition is permanently lost once the group is exploded or erased from a drawing.
14. (T or F) Block use is limited to a single drawing.

List the two block commands.

- 15.
- 16.
17. Groups of blocks are often assembled in useful packages called _____.

What are the two types of block library?

- 18.
- 19.

Accessing blocks that are part of a (20) library is faster than accessing blocks that are part of a (21) library.

- 20.
- 21.
22. If the objects used to make a block are created on layer *text*, they will have the characteristics of (layer *text*, the current layer) when inserted.
23. Generally speaking, the user should always create objects for blocks on layer _____.
24. Use the _____ command to create folder libraries.

25. What is the command used to place a block in a drawing?
26. (T or F) A Group consists of objects which can be manipulated as a group, or individually.
27. (T or F) To move the individual objects of a group, the group must be exploded like a polyline.
28. (T or F) If a group is selectable, it can be manipulated as a single object within the drawing.
29. (T or F) Begin the Group command by typing “group” or “g” at the command prompt. There is no Group button on the ribbon's Draw or Modify panels.
30. Using the Object Grouping dialog box, you can
 - a. move the objects in a group
 - b. erase the objects in a group
 - c. explode a group.
31. (T or F) An exploded Group loses all group definition.
32. (T or F) A group is specific to the drawing in which it was created and can not be used in any other drawing.
33. When the user picks the Make Block button, AutoCAD displays:
 - a. a preview icon frame
 - b. the Block Definition dialog box
 - c. a select objects button.
34. (T or F) You must enter the X, Y, and Z coordinates into the appropriate text boxes of the Block Definition dialog box to identify the insertion point for the block.
35. (T or F) The Write Block (WBlock) differs from a block in that a block will be found only in the drawing in which it was created, whereas a WBlock will become a separate drawing file with a DWG extension.
36. (T or F) Type “-w” to insert a block.
37. (T or F) “W” is the hotkey for the WBlock command.
38. (T or F) In the Source frame of the Write Block dialog box, a bullet next to “Entire Drawing” will cause AutoCAD to prompt you to select objects from which to create a block.
39. The Destination Section of the Write Block dialog box does not contain a text box for the new file's
 - a. file name
 - b. base point
 - c. location
 - d. insert units.
40. (T or F) The Block command is used to insert a block into a drawing.
41. (T or F) Pick the Insert button to activate the command line approach of the Insert command.
42. (T or F) Picking the Insert Block button on the ribbon's Block panel will call the Insert dialog box.
43. (T or F) If the block name is not visible in the Insert dialog box, the user has lost the block.
44. (T or F) Once you have dropped the iDrop block into the drawing, AutoCAD presents the Insert dialog box.

45. (T or F) If created properly, you can create a single *sink* block to provide either an oval or a rectangular sink fixture.
46. (T or F) When manipulating a table and chair dynamic block, you can adjust the table to one of several pre-defined lengths or widths.
47. (T or F) That same table and chair dynamic block can automatically adjust the number of chairs to fit the table's length.
48. Use the _____ command to access AutoCAD's block editor.
49. In the block editor, use _____ to provide several shapes for a specified object (such as round or oval sinks, square or rectangular chairs, etc.).
50. (T or F) A dynamic block parameter is always useless without an accompanying action.
51. Use the _____ parameter to allow a user to mirror a block.
52. A user will use _____ to alter a dynamic block once it's been inserted.
53. Both visibility and lookup grips appear as _____ .
54. AutoCAD provides parameter/action sets on the _____ tab of the Block Authoring Palettes. Use the (55) or (56) option of the Linear parameter to make preset block sizes available for the user.
- 55.
- 56.
57. (T or F) Using dynamic blocks, it's possible to provide more than one insertion point for a block.

Answers

- | | | |
|----------------------|----------------|-----------------------|
| 1. Groups | 20. Template | 39. b |
| 2. Blocks | 21. Folder | 40. F |
| 3. Group | 22. Layer Text | 41. F |
| 4. Selectable | 23. 0 | 42. T |
| 5. No | 24. WBlock | 43. F |
| 6. F | 25. Insert | 44. F |
| 7. Highlight | 26. T | 45. T |
| 8. Rename | 27. F | 46. T |
| 9. Explode | 28. T | 47. T |
| 10. Selectable | 29. T | 48. BEdit |
| 11. F | 30. c | 49. Visibility States |
| 12. T | 31. T | 50. F |
| 13. T | 32. T | 51. Flip |
| 14. F | 33. b | 52. Grips |
| 15. Block (or bmake) | 34. F | 53. Arrows |
| 16. WBlock | 35. T | 54. Parameter Sets |
| 17. Libraries | 36. F | 55. List |
| 18. Template Files | 37. T | 56. Increment |
| 19. Folders | 38. F | 57. T |