

AutoCAD 2008: One Step at a Time

Lesson 19: Hatching and Filling

08R19 Exercises

1. Use the following information to create the Sample Piping Standard detail sheet. Save the drawing as *MyTee* in the C:\Steps\Lesson19 folder.

- 1.1. Layer Information (at right).
- 1.2. Limits: 0,0 to 17,11
- 1.3. Grid spacing = 1/4"
- 1.4. Text sizes = 3/8", 1/4", 3/16", 1/8"
- 1.5. Font: Times New Roman
- 1.6. Hatching information
 - 1.6.1. Pattern = ANSI32
 - 1.6.2. Scale = 1"
 - 1.6.3. Angle = 0

LAYER NAME	COLOR	LINETYPE
0	7 (white)	Continuous
Border	5 (blue)	Continuous
Cl	3 (green)	Center
Dim	5 (blue)	Continuous
Hatch	32	Continuous
Marker	6 (magenta)	Continuous
Ob	1 (red)	Continuous
Text	6 (magenta)	Continuous

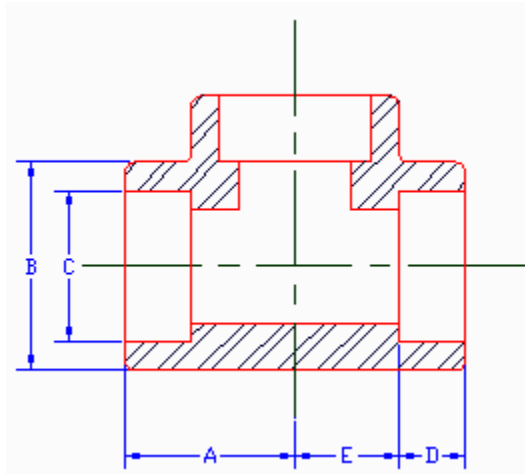

Dimensions (Inches)										
Nominal Pipe Size	1/8	1/4	1/2	3/4	1	1 1/4	1 1/2	2	2 1/2	3
A	7/8	7/8	1 1/8	1 5/16	1 1/2	1 3/4	2	2 3/8	3	3 3/8
B	29/32	29/32	1 5/16	1 9/16	1 3/4	2 7/32	2 1/2	3 1/32	3 5/8	4 5/16
C	.420	.555	.850	1.08	1.340	1.680	2	2.406	2.906	3.535
D	7/16	7/16	1/2	9/16	5/8	11/16	3/4	7/8	1 3/8	1 1/8
E	7/16	7/16	5/8	3/4	7/8	1 1/16	1 1/4	1 1/2	1 5/8	2 1/4

North Harris College

Sample Piping Standard: Socket Weld Tee

Drawn By: T. Jefferson

Checked By: B. Franklin

Project No.: 1001-A1A

Date: June 6, 1944

Scale: NTS

Approval: FDR

Sht: 1 of: 15

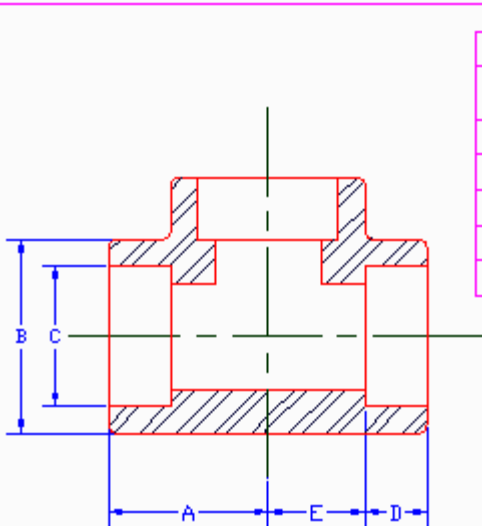

Dimensions (Inches)										
Nominal Pipe Size	1/8	1/4	1/2	3/4	1	1 1/4	1 1/2	2	2 1/2	3
A	7/8	7/8	1 1/8	1 5/16	1 1/2	1 3/4	2	2 3/8	3	3 3/8
B	29/32	29/32	1 5/16	1 9/16	1 3/4	2 7/32	2 1/2	3 1/32	3 5/8	4 5/16
C	.420	.555	.850	1.08	1.340	1.680	2	2.406	2.906	3.535
D	7/16	7/16	1/2	9/16	5/8	11/16	3/4	7/8	13/8	1 1/8
E	7/16	7/16	5/8	3/4	7/8	1 1/16	1 1/4	1 1/2	1 5/8	2 1/4

North Harris College

Sample Piping Standard: Socket Weld Tee

Drawn By: T. Jefferson

Checked By: B. Franklin

Project No.: 1001-A1A

Date: June 6, 1944

Scale: NTS

Approval: FDR

Sht: 1 of: 15

2. Start a new drawing from scratch.

2.1. Create the following setup:

2.1.1. Use a 1½"=1'-0" scale on an A-size sheet of paper (8½x11)

2.1.2. Grid: 1" (snap as needed)

2.1.3. The layers in the table.

2.2. Use this information for the Grade hatching:

Pattern: EARTH

Scale: 8.0000

Angle: 45

2.3. Use this information for the sand hatching:

Pattern: AR-SAND

Scale: 0.5000

Angle: 0

2.4. Use the Times

New Roman font.

Large text should

plot at ¼"; small

text should plot at

1/8".

2.5. Create the

Exterior Slab

drawing. Save it

as *MySlab* in the

C:\Steps\

Lesson19 folder.

LAYER NAME	COLOR	LINETYPE
0	7 (white)	Continuous
Border	5 (blue)	Continuous
Cl	6 (magenta)	Center2
Dim	2 (yellow)	Continuous
Const	1 (red)	Continuous
Hidden	42	Hidden
Obj1	4 (cyan)	Continuous
Obj2	3 (green)	Continuous
Obj3	1 (red)	Continuous
Obj4	6 (magenta)	Continuous
Text	2 (yellow)	Continuous

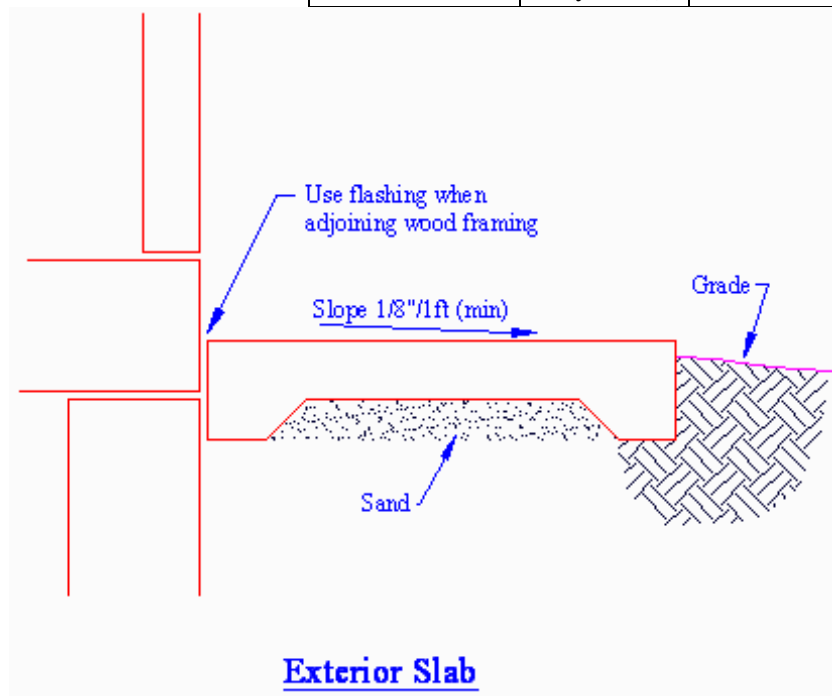

3. Start a new drawing from scratch. Using the same information you used in the *Exterior Slab* drawing in Exercise 2, create the *Concrete Pier Footing* drawing in Figure 18.031.

- 3.1. Use this information to hatch the concrete:

Pattern: AR-
CONC

Scale: 0.5000

Angle: 0

- 3.2. Save the drawing as *MyFooting* in the C:\Steps\Lesson19 folder.

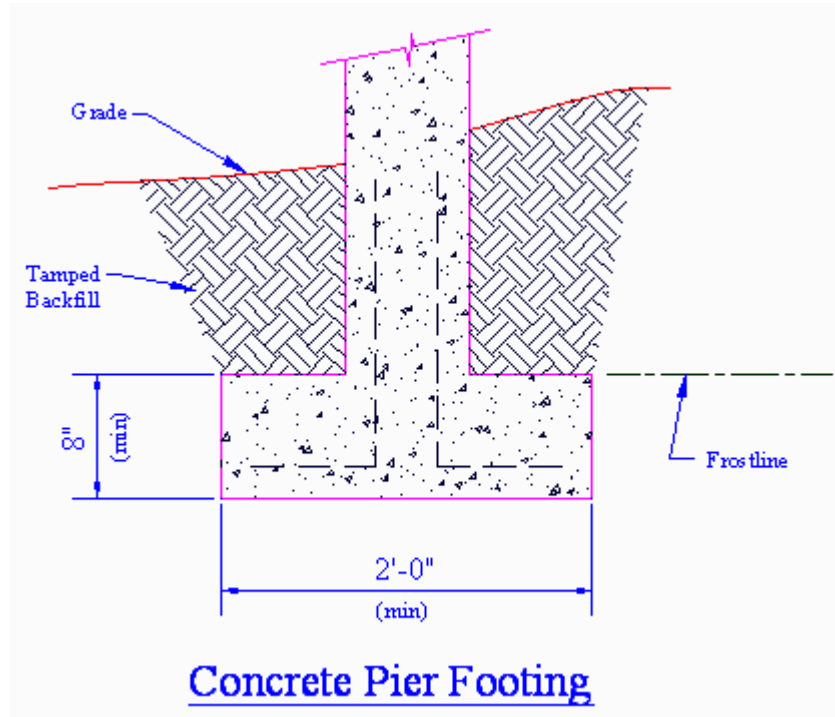

4. Open the *Cabin-hatch.dwg* file in the C:\Steps\Lesson19 folder. Use the following information to complete the drawing. The completed elevations are shown. (See if you can add a chimney on your own.)

4.1. Create the additional layers shown.

4.2. Hatching information:

LAYER NAME	COLOR	LINETYPE
Hatch1	85	Continuous
Hatch2	22	Continuous
Hatch3	44	Center
Hatch4	214	Continuous

▪ Doors:

Pattern: AR-RROOF

Scale = 1/4"

Angle = 90°

Layer = Hatch3

▪ Roof:

Pattern: AR-RSHKE

Scale = 1/16"

Angle = 0°

Layer = Hatch3

▪ Facade:

Pattern: AR-BRELM

Scale = 1/8"

Angle = 0°

Layer = Hatch2

▪ Curtains:

Pattern: STARS

Scale = 1"

Angle = 90°

Layer = Hatch4

▪ Gables:

Pattern: ANSI31

Scale = 1"

Angle = 45°

Layer = Hatch2

▪ Doorknobs are on the Hatch1 layer.

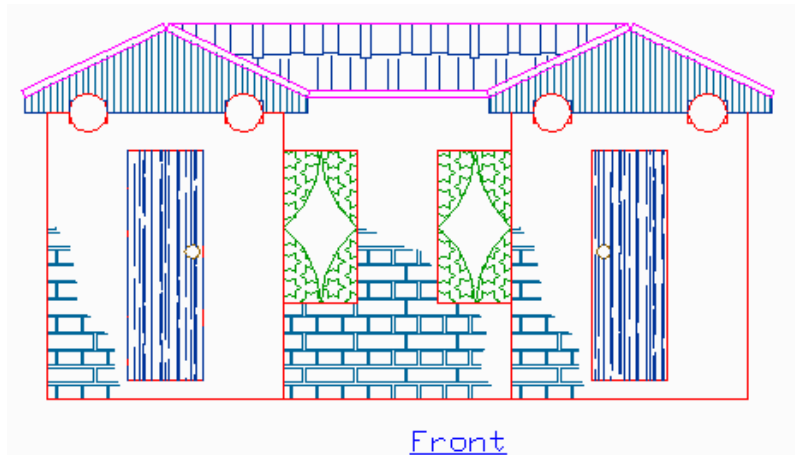

Front Elevation

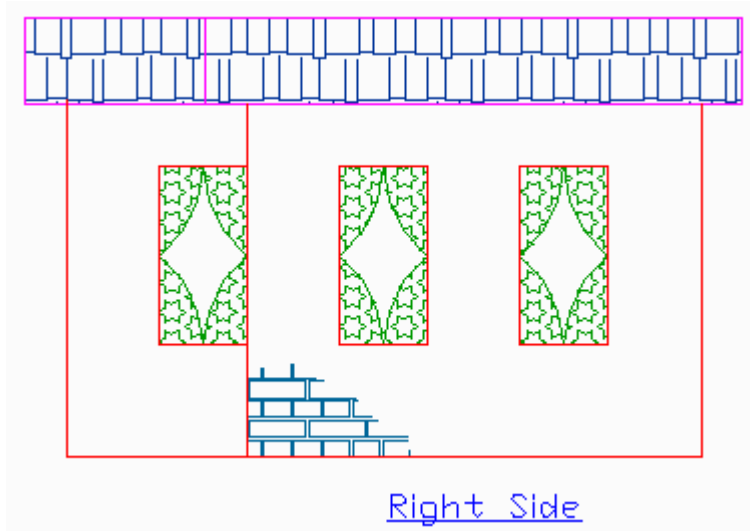

Side Elevation

5. Using what you've learned, create the following drawings. The grid, where shown, is 2".

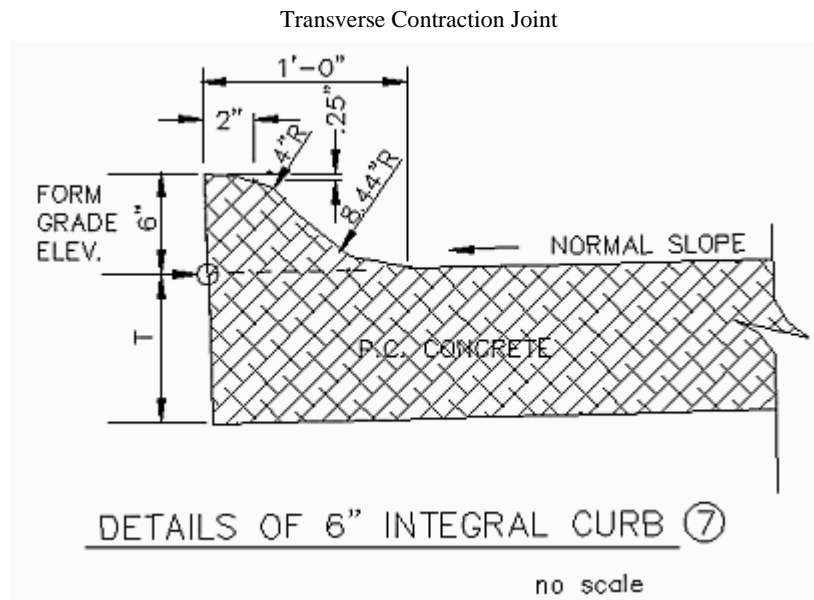
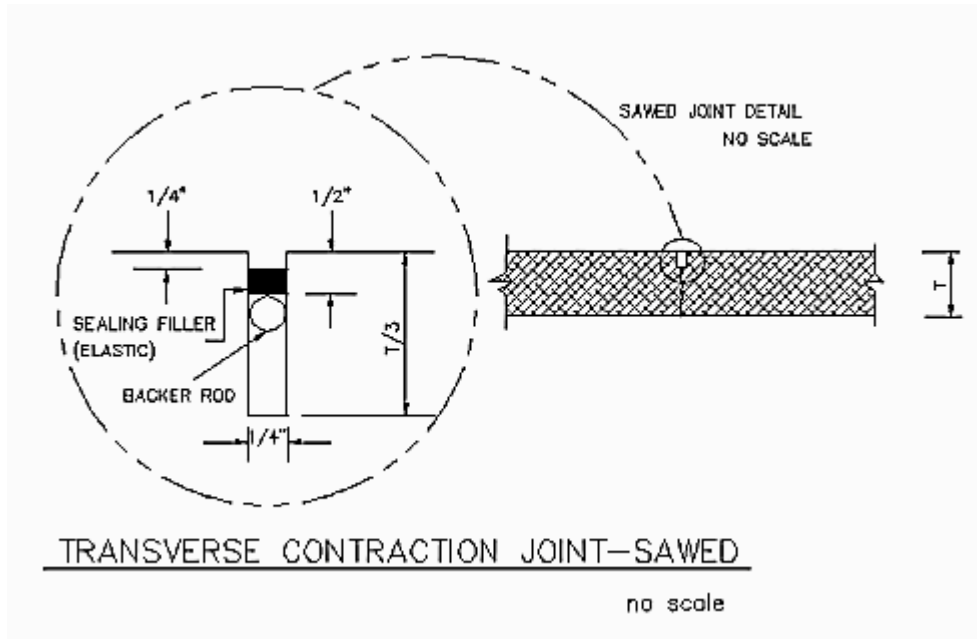

Integral Curb

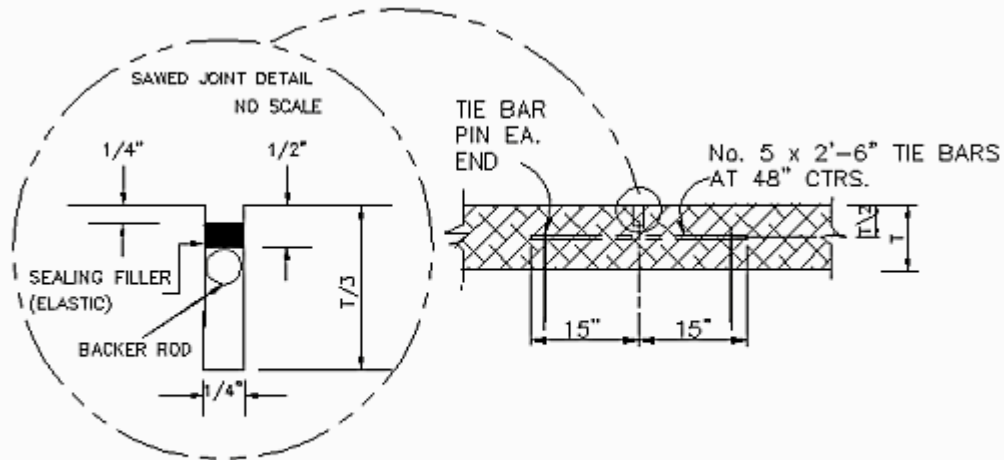

LONGITUDINAL JOINT — SAWED ③
no scale

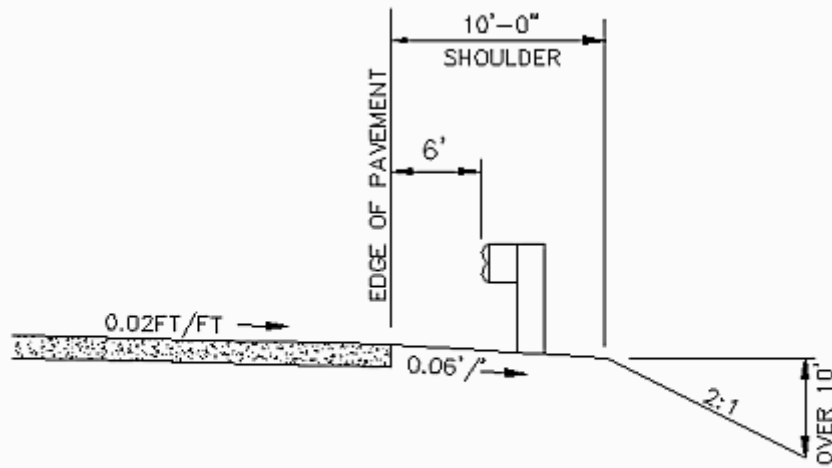

GUARDRAIL DETAIL

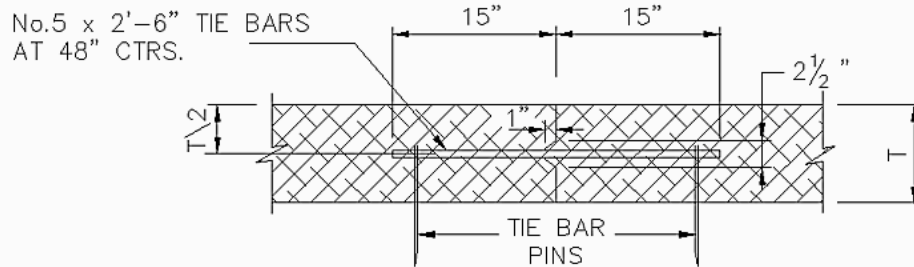

LONGITUDINAL JOINT — KEYED
no scale

6. Using what you've learned, create the following drawing.

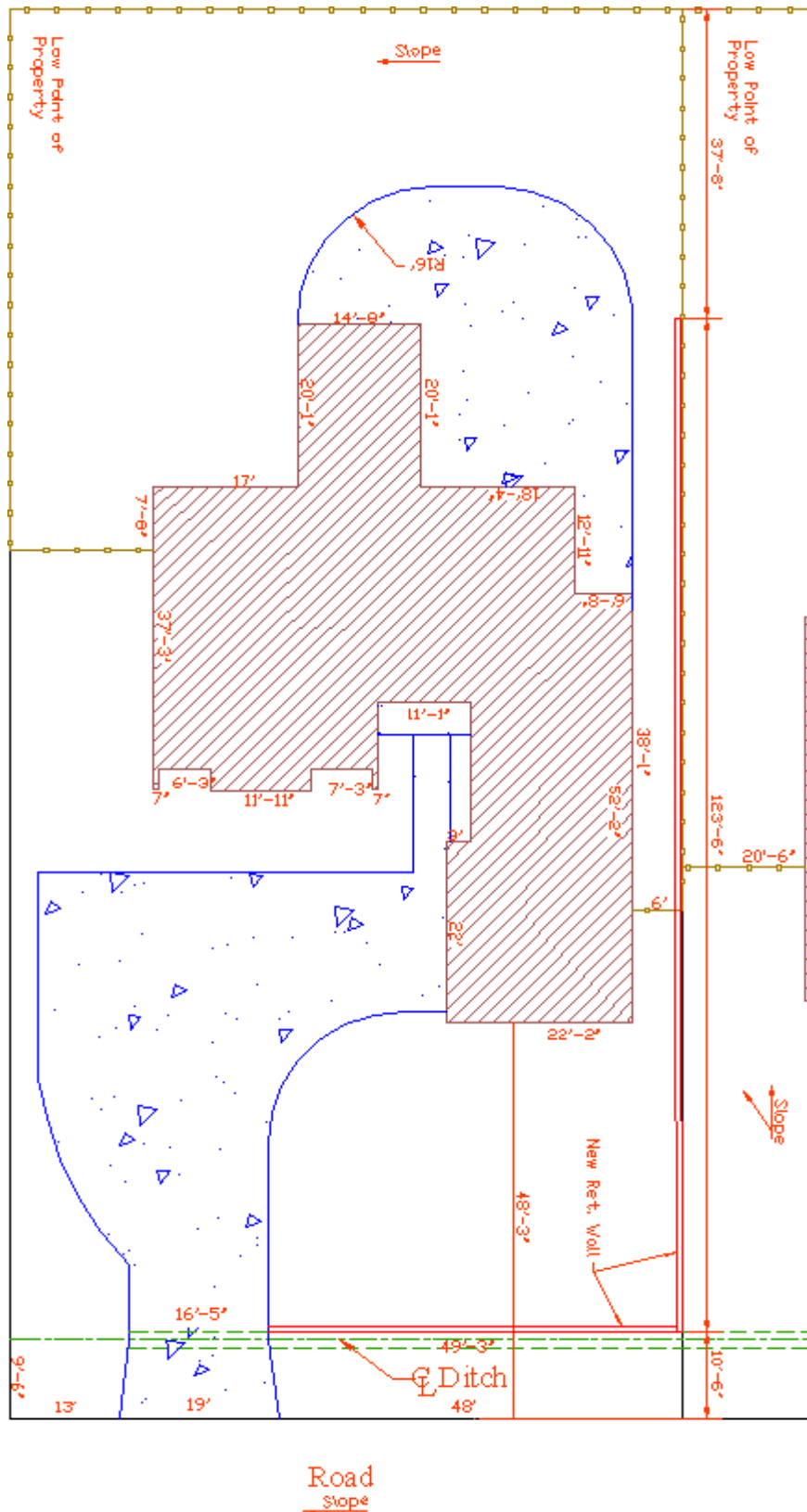

Write your answers on a separate sheet of paper.

1. Section lines are created as a style of _____.
2. The _____ hatch pattern will present the same results as the Solid command.

The User Defined option of the hatch command allows the user to create a hatch pattern by defining the (3) and (4) of hatch lines.

- 3.
- 4.
5. (T or F) A hatch angle of 0° will always draw the hatch lines horizontally.
6. (T or F) You can adjust a brick hatch pattern so that the “first” brick lies at a specified location.

The three AutoCAD hatch styles include: (7) which recognizes multiple objects and hatches every other one; (8) which hatches only between the outer two boundaries; and (9) which ignores all but the outermost boundary.

- 7.
- 9.
- 8.
10. (T or F) It's necessary that all hatch boundaries be completely closed for the hatching to work properly.
11. Pick on the _____ button in the Hatch and Gradient dialog box to see the Hatch Pattern Palette.
12. The Iso Pen Width option is only available when the user selects to use an _____ pattern.
13. _____ hatching means that the hatching will automatically update when the boundary changes.
14. Use the _____ button to match an existing hatch style.
15. Using the _____ button on the Hatch and Gradient dialog box enables the user to simply pick a point within a boundary where hatching is required.
16. A boundary within a boundary is called an _____.
17. Use the _____ command to modify existing hatching.
18. What can the user do to turn classroom-acquired skills into actual knowledge?
19. (T or F) Filling an area with lines or symbols to illustrate a particular condition is called hatching.
20. (T or F) In AutoCAD, section lines are a form of hatch pattern.
21. (T or F) AutoCAD's Normal style of hatching will recognize individual parts or islands in a drawing and not hatch them.

22. (T or F) Use the Hatch command to access the Hatch and Gradient dialog box.
23. (T or F) The Add: Pick Points button in the Hatch and Gradient dialog box is too confusing to be of much use.
24. (T or F) AutoCAD does not permit the user to view the hatch application before it is completed.
25. (T or F) When using the Add: Pick Points button on the Hatch and Gradient dialog box, AutoCAD requires that the user select an object to hatch.
26. (T or F) If you pick an associative hatch pattern created via the Hatch and Gradient dialog box, then the Hatch Edit option will appear on the cursor menu.
27. (T or F) The operator can change an associative hatch pattern by selecting a new one in the Pattern control box of the Hatch Edit dialog box.
28. (T or F) You can set up hatching to automatically rescale with changes in the drawing's Annotation scale.

Answers

- | | |
|------------------------|----------------------|
| 1. Hatch Pattern | 15. Add: Pick Points |
| 2. Solid | 16. Island |
| 3. Angle | 17. Hatchedit |
| 4. Spacing | 18. Practice |
| 5. F | 19. T |
| 6. T | 20. T |
| 7. Normal | 21. T |
| 8. Outer | 22. T |
| 9. Ignore | 23. F |
| 10. F | 24. F |
| 11. Pattern | 25. F |
| 12. ISO | 26. T |
| 13. Associative | 27. T |
| 14. Inherit Properties | 28. T |