

AutoCAD 2008: One Step at a Time
Lesson 16: Basic Dimensioning

08R16	Exercises
--------------	------------------

1. Dimension drawings *Iso1* and *Iso2* in the C:\Steps\Lesson16 folder. They'll look like the following figures when completed.

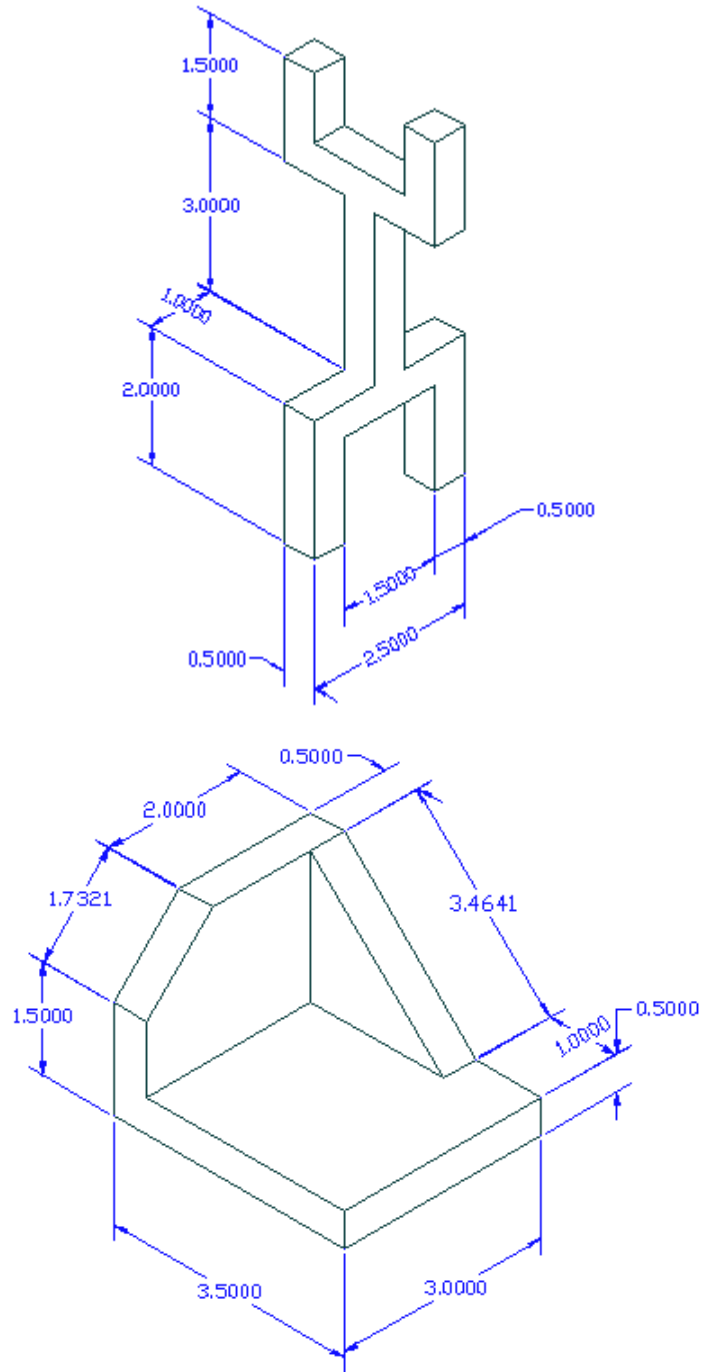

2. Dimension the *Brake.dwg* file in the C:\Steps\Lesson16 folder.

Remember:

- the *Dimaso* command toggles associative and normal dimensioning
- the *Explode* command converts an associative dimension to a normal dimension.
- dimensions don't always fall where you want them, so remember your editing commands.

The drawing will look like this when complete.

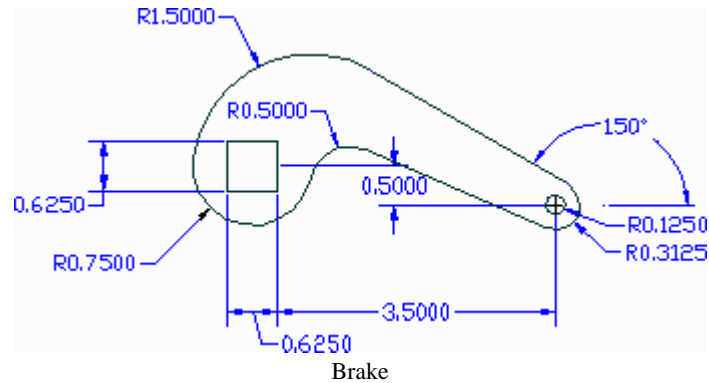

3. Dimension the *Pulley-slider.dwg* file in the C:\Steps\Lesson16 folder. The drawing will look like this when completed.

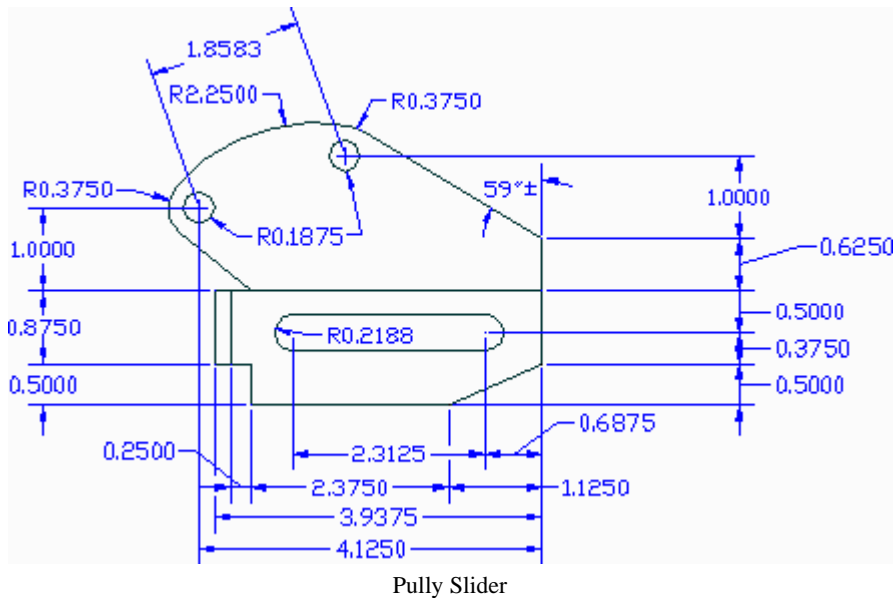

4. Add the dimensions shown to the *MyBracket* drawing you created in Lesson 7 (or you can use the *Bracket14.dwg* file found in the C:\Steps\Lesson16 folder). Your drawing will look like the figure below when completed.

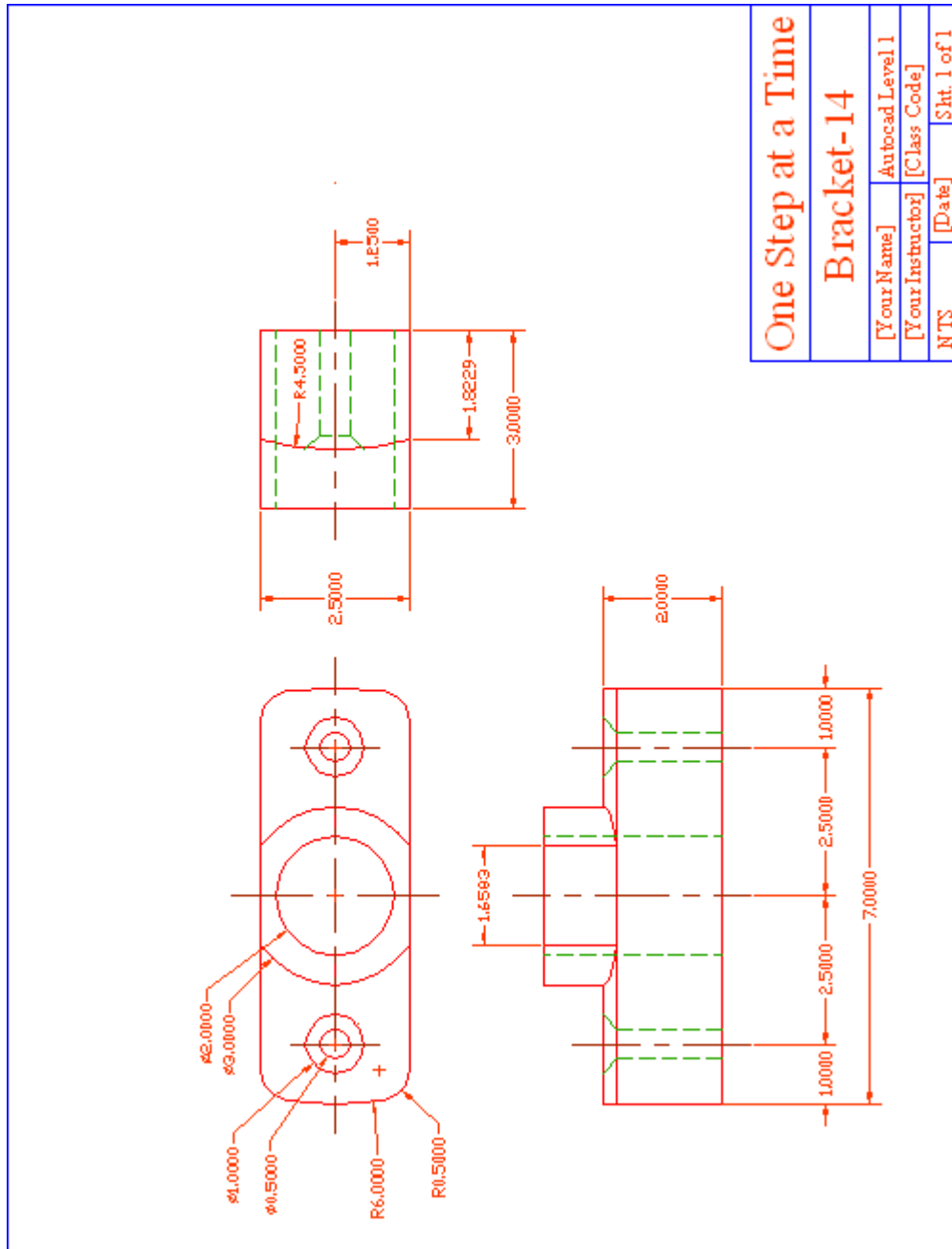

5. Add the dimensions shown to the *MyGear* drawing you created in Lesson 9 (or you can use the *gear14.dwg* file found in the C:\Steps\Lesson16 folder). Your drawing will look like the following figure when completed.

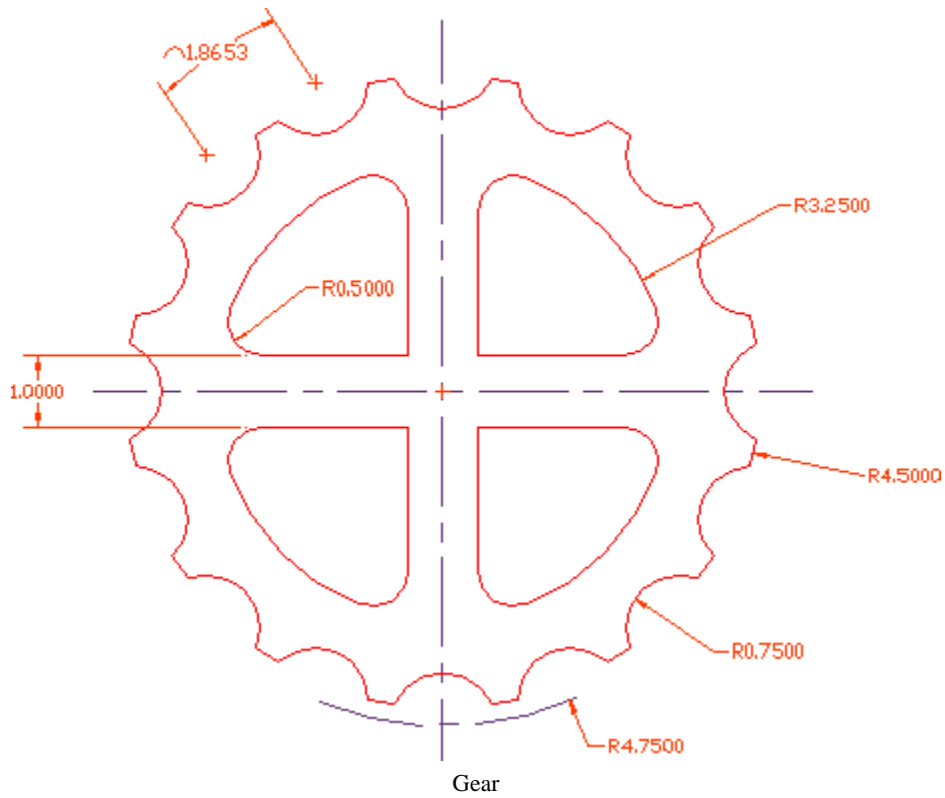

Write your answers on a separate sheet of paper.

Identify.

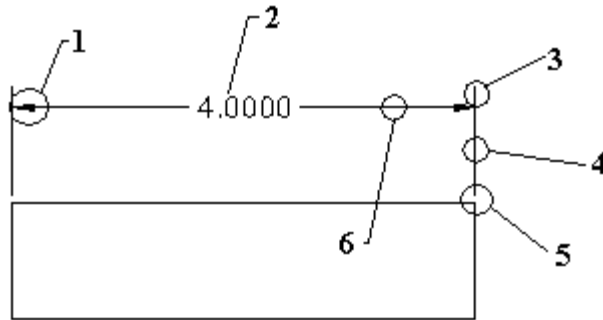

- 1.
 - 2.
 - 3.
 - 4.
 - 5.
 - 6.
 7. AutoCAD defaults to _____ units when dimensioning regardless of the units the drawing has been set up to use.
 - (8) dimensions are tied to the objects being dimensioned and (9) dimensions are not.
 - 8.
 - 9.
 10. (T or F) The user cannot break or trim extension lines on an associative dimension.
 11. What is the system variable (command) that controls associative / normal dimensioning?
 12. Use the _____ command to convert associative dimensions to normal dimension.
- List ten dimension commands.
- 13.
 - 14.
 - 15.
 - 16.
 - 17.
 - 18.
 - 19.
 - 20.
 - 21.
 - 22.
 23. When using the **Press Enter to Select** option in dimensioning, (the user, AutoCAD) determines the endpoints of the object being dimensioned.
 24. If allowed, AutoCAD will determine the location of the linear dimension by the location of the _____.

25. The _____ option of the Dimlinear command allows the user to rotate the dimension text for a better fit.
 26. Use the _____ command to dimension angles, circles, and arcs.
 27. (T or F) When dimensioning diameters or radii, it's necessary for the user to enter the diameter symbol (by holding down the control key while typing D or R).
 28. Use the _____ command to create a continuous string of dimensions.
 29. & 30. Whereas Dimcontinue works off of the (first, last) extension line origin, Dimbaseline works off of the (first, last).
 31. Use the _____ command to place simple call outs that require an arrow or line to reference an object.
 32. _____ places a dimension that is a distance from the 0,0 coordinate of the drawing.
 33. In editing Associative Dimensions, the user will generally change or rotate the text or change the angle of the extension lines with the _____ command.
 34. The user can change the position of associative dimension text using the _____ command.
 35. To edit the dimension text in a normal dimension, use the _____ command.
- When dimensioning isometrics, you must use the (36) option of the (37) command to orient the dimension in the correct isometric plane.
- 36.
 - 37.
 38. Use the _____ command to place dimensions on an isometric drawing.

Identify these buttons.



39. 40. 41. 42. 43.



44. 45. 46. 47. 48.

49. (T or F) The user may access linear dimensioning by typing dli or picking the Linear Dimension button on the dimension control panel.
50. (T or F) Use the DimLinHor command to draw horizontal dimensions and the DimLinVer command for vertical dimensions.
51. (T or F) At the Dimlinear command prompt, the user can hit enter and select an object. AutoCAD will then locate the dimension's extension lines at the endpoints of that object.
52. (T or F) By default, the Dimangular command prompts the user to specify the vertex of the angle.

53. (T or F) After selecting two lines for an angular dimension, the dimension will automatically be placed when you hit Enter.
54. (T or F) After terminating a command you may reenter this command by hitting the Enter key.
55. (T or F) Radial dimension text cannot be changed.
56. (T or F) The command sequences for the Dimradius and Dimdiameter commands are the same.
57. (T or F) When dimensioning diameters, the user should remember to enter %%d for the diameter symbol.
58. (T or F) Aligned dimensions run perpendicular to the first extension line origin.
59. (T or F) The Dimaligned command resembles the Dimlinear command.
60. (T or F) QDim automatically dimension a selected group of objects.
61. (T or F) The Edit option of the QDim command allows the user to edit the dimension text.
62. (T or F) Dimensioning an isometric drawing with Dimaligned will produce an isometric dimension.
63. (T or F) Use the Oblique option of the Dimedit to change an aligned dimension into an isometric dimension.
64. Use the _____ command to dimension part of an arc.
65. Use the _____ command to adjust the spacing of baseline dimensions.
66. When a callout overlaps a dimension line, use the _____ command to automatically remove the dimension line around the text.
67. (T or F) The MLeader command can place bubbled callouts.
68. To align leaders, use the _____ command.
69. To gather bubbled leaders into a single leader, use the _____ command.

Answers

- | | | |
|-------------------|-----------------|--------------------|
| 1. Arrow | Qdim | 45. Dimlinear |
| 2. Dimension | DimInspect | 46. Dimtedit |
| 3. Extension Line | DimBreak | 47. Quick Leader |
| Extension | DimSpace | 48. Dimordinate |
| 4. Extension line | 23. AutoCAD | 49. T |
| 5. Extension line | 24. Crosshairs | 50. F |
| origin offset | 25. Angle | 51. T |
| 6. Dimension line | 26. Dimangular | 52. T |
| 7. Decimal | 27. F | 53. F |
| 8. Associative | 28. Dimcontinue | 54. T |
| 9. Normal | 29. Last | 55. F |
| 10. F | 30. First | 56. T |
| 11. Dimaso | 31. MLeader | 57. F |
| 12. Explode | 32. Dimordinate | 58. F |
| 13-22 (any ten) | 33. Dimedit | 59. T |
| Dimlinear | 34. Dimtedit | 60. T |
| Dimangular | 35. DDEdit | 61. F |
| Dimradius | 36. Oblique | 62. F |
| Dimdiameter | 37. Dimedit | 63. T |
| Dimcontinue | 38. Dimaligned | 64. DimArc |
| Dimaligned | 39. Dimaligned | 65. DimSpace |
| Dimbaseline | 40. Dimangular | 66. DimBreak |
| Dimordinate | 41. Dimbaseline | 67. T |
| Dimarc | 42. Dimcontinue | 68. MLeaderAlign |
| Dimjogged | 43. Dimdiameter | 69. MLeaderCollect |
| Dimjogline | 44. Dimedit | |