

AutoCAD 2008: One Step at a Time Lesson 12: Advanced Modification Techniques

08R12

Exercises

I've modified an earlier project for our first Lesson 12 exercise. This should give you some frame of reference when you compare different modifying commands and methods.

1. Open the *Cabin-adv.dwg* file in the C:\Steps\Lesson12 folder.
 - 1.1. Using the objects provided, the grips procedure, and your preferences in the Options dialog box, complete the drawing shown.
 - 1.2. Save the drawing as *MyCabin-adv.dwg* in the C:\Steps\Lesson12 folder.

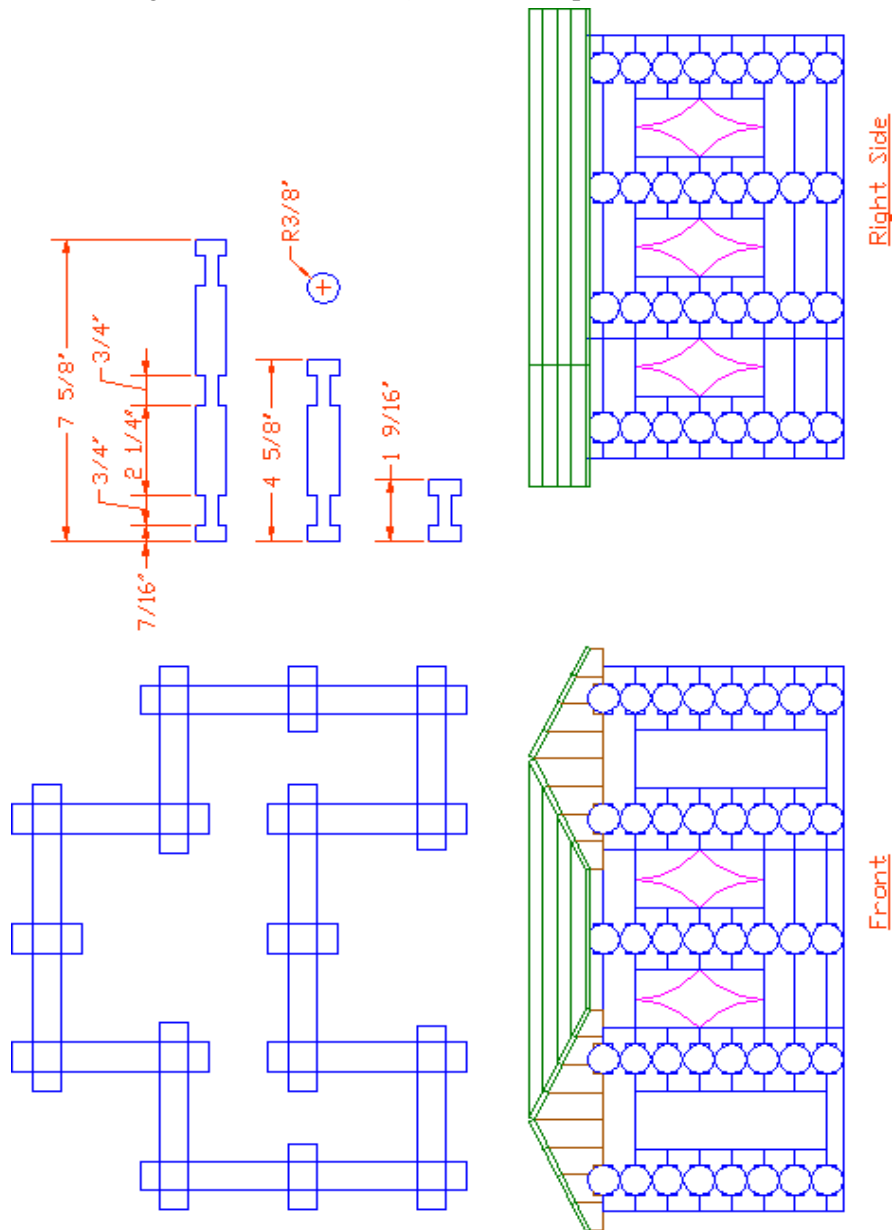

2. Start a new drawing from scratch.

2.1. Use the following setup:

- 2.1.1. Grid: $\frac{1}{2}$
- 2.1.2. Snap and Layers: as needed
- 2.1.3. Font: Times New Roman
- 2.1.4. Dimension styles: as needed

2.2. Create the drawing at right.

2.3. Save the drawing as *MyGasket* in the C:\Steps\Lesson12 folder.

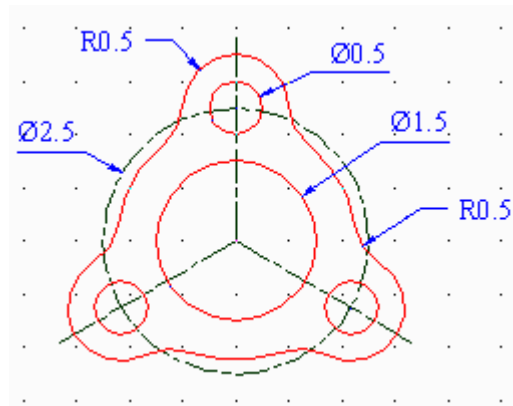

3. Start a new drawing from scratch.

3.1. Use the setup described in Exercise #2.

3.2. Save the drawing as *MySlottedGuide* in the C:\Steps\Lesson12 folder.

3.3. Create the drawing.

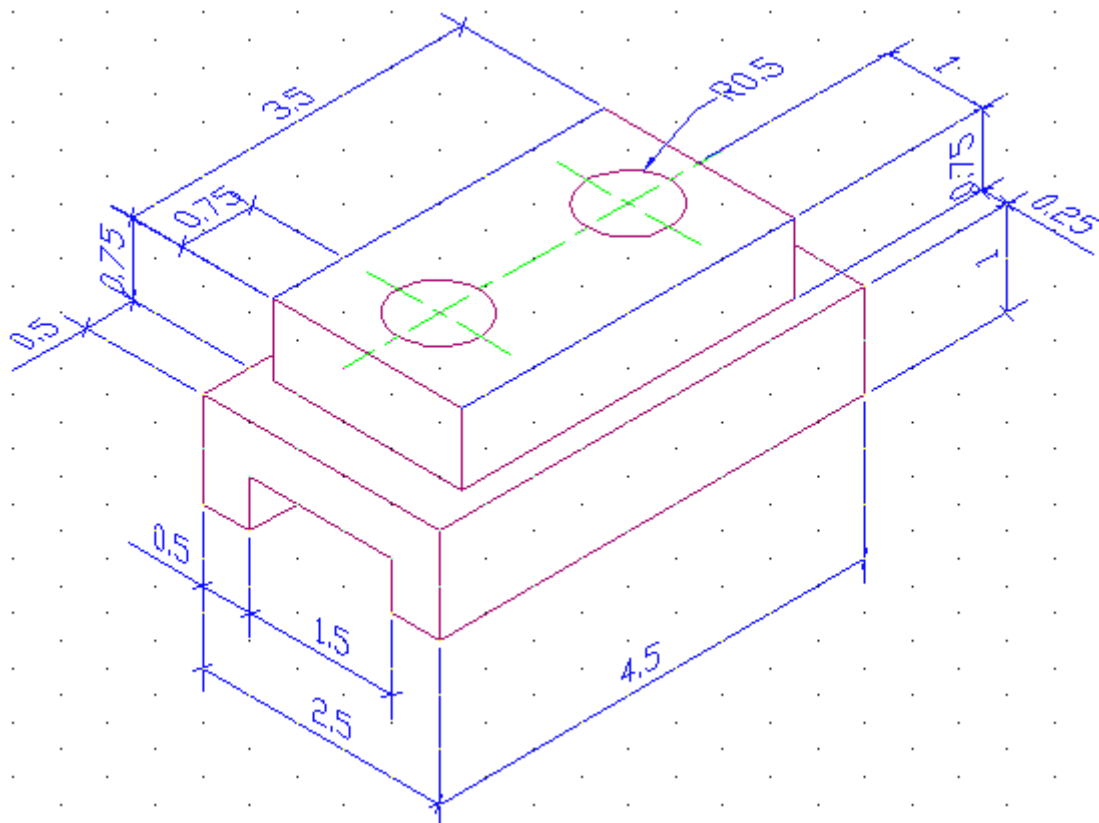

Slotted Guide

4. Start a new drawing from scratch.
 - 4.1. Repeat the setup you did in Exercises 2 and 3.
 - 4.2. Save the drawing as *MySpring* in the C:\Steps\Lesson12 folder.
 - 4.3. Create the spring drawing.

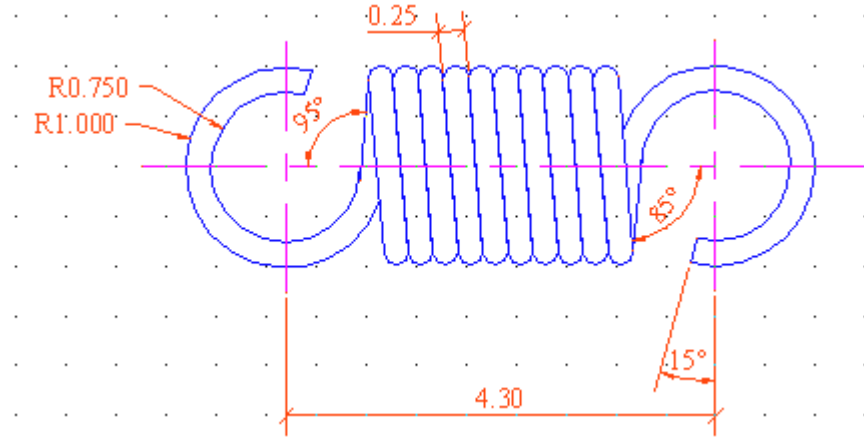

Spring

5. Create and dimension the Measuring Cups. The grid is set to 1/4". Use appropriate layers.

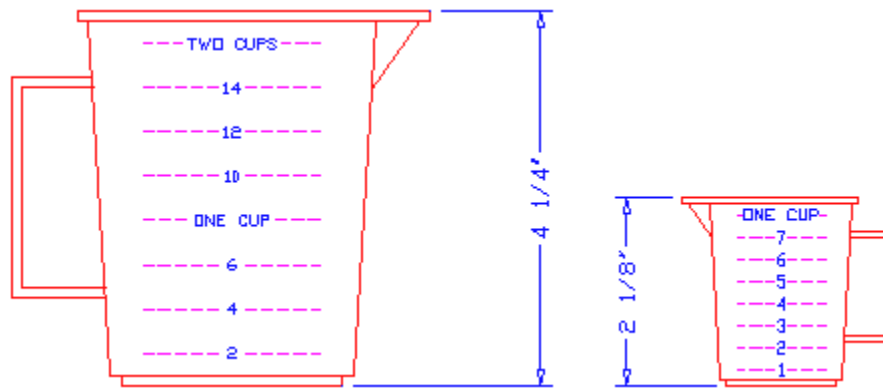

Measuring Cups

6. Using the bottle detail at right, create the drawing of the spice rack (below). The grid is 1/8". Fully dimension the drawing (not the bottles) and use appropriate layers.

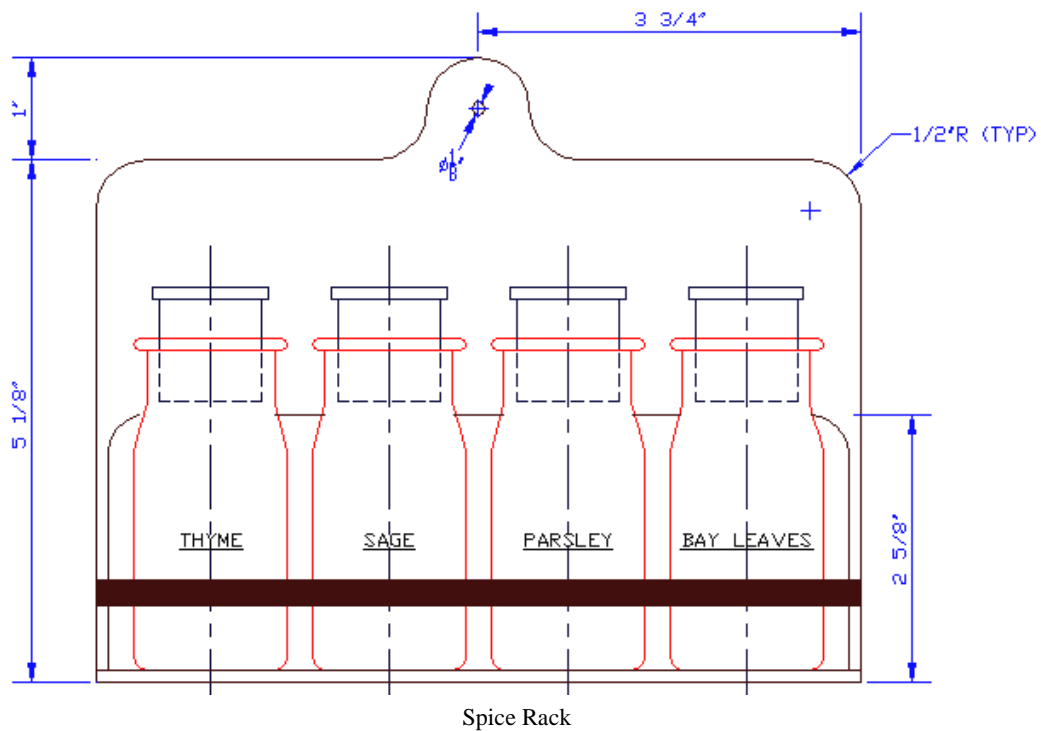
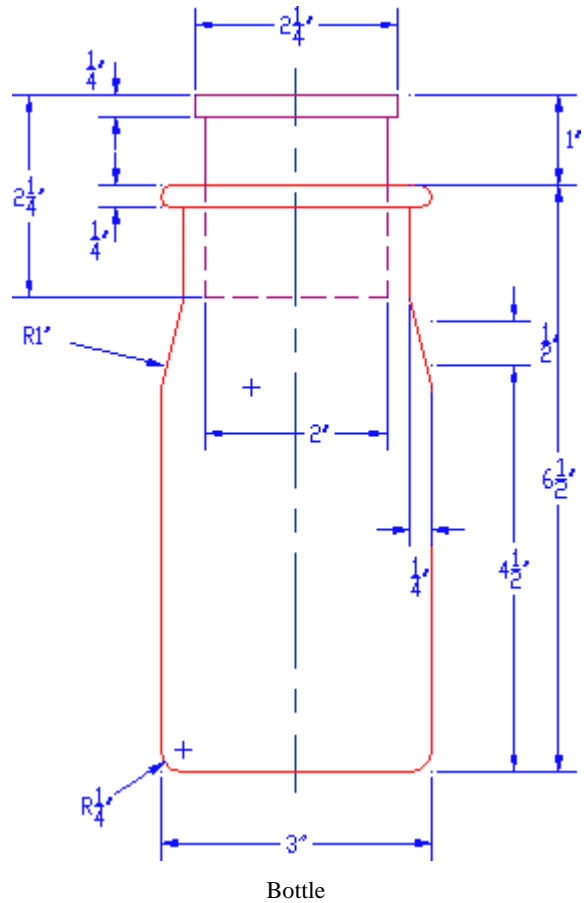

Write your answers on a separate sheet of paper.

1. Normal command procedures – giving a command then selecting the object of the command – can be called (Noun/Verb selection, Verb/Noun selection).
2. Access the Options dialog box by typing _____ at the command prompt.
3. Turn grips off by giving the grips system variable a value of _____.
4. The system variable for Noun/Verb selection is _____.
5. Its default value is _____.
6. If the Use Shift to Add box in the Options dialog box has a check in it, the user must hold down the _____ key to select more than one object.
7. The sysvar for Use Shift to Add is _____.
8. Its default value is _____.
9. The sysvar for Press and Drag is _____.
10. Its default value is _____.
11. _____ enables us to pick an open area of the drawing to automatically begin a selection window.
12. The sysvar for this is _____.
13. Its default value is _____.
14. To change the size of the pickbox from the command line, type _____.
15. _____ are control points located on all objects, blocks, and groups.

List the five modification commands available using grips.

16. _____
17. _____
18. _____
19. _____
20. _____
21. The _____ command is also available as an option for each of the primary grip commands.
22. To clear grips, hit the _____ key.
23. To remove an object from a grips selection set, hold down the _____ key while selecting it.
24. The user toggles through the available grips commands by hitting the _____.
25. (T or F) There is no way to offset objects using grips.
26. Any time you've selected a grip, you can _____ in the drawing area to access a cursor menu that provides the same options as the command line.

27. (T or F) Using the Move Grips command, all the objects with active grips will move.
28. (T or F) Grips are control points indicated by tiny blue squares on all objects, blocks, and groups.
29. (T or F) Arcs will have a center grip like circles.
30. (T or F) Circles have grips at all four quadrants (at angles of 0 degrees, 90 degrees, 180 degrees, and 270 degrees) and at the center.
31. (T or F) A setting of 1 at the Grips command will activate grips.
32. (T or F) Polylines have grips only at their endpoints.
33. (T or F) Grips cannot be removed from objects.

Answers

- | | |
|------------------------|-----------------|
| 1. Verb/Noun Selection | 18. Rotate |
| 2. Options (or op) | 19. Scale |
| 3. 0 | 20. Mirror |
| 4. Pickfirst | 21. Copy |
| 5. 1 | 22. ESC |
| 6. SHIFT | 23. SHIFT |
| 7. Pickadd | 24. Spacebar |
| 8. 1 | 25. F |
| 9. Pickdrag | 26. Right-click |
| 10. 0 | 27. T |
| 11. Implied Windowing | 28. T |
| 12. Pickauto | 29. T |
| 13. 1 | 30. T |
| 14. Pickbox | 31. T |
| 15. Grips | 32. F |
| 16. Stretch | 33. T |
| 17. Move | |