

## AutoCAD 2008: One Step at a Time

### Lesson 7: Color, Linetype, and More Made Simple - Layers

**08R7**

#### Exercises

1. Create the remote control drawing at right using the following setup. Save the drawing as *MyRemote* in the C:\Steps\Lesson07 folder.

Layer Names	Color	Linetype
Button	62	continuous
Dim	cyan	continuous
Obj	211	continuous
Text	yellow	continuous
Toggle	blue	continuous
Up-Down	211	continuous

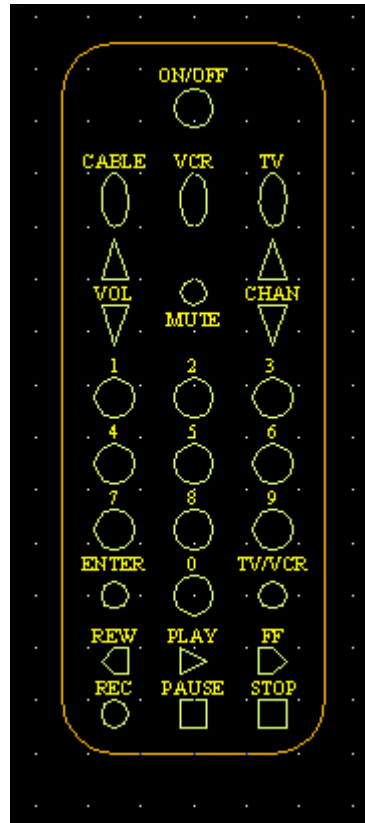

- 1.1. Lower left limits: 0,0
- 1.2. Upper right limits: 6,10
- 1.3. Architectural units
- 1.4. Grid: 1/4"
- 1.5. Snap: as needed
- 1.6. Font: Times New Roman
- 1.7. Text Height: 1/8

2. Set up a drawing to be used in the Lesson 9 exercises. Use the following parameters:

- 2.1. Lower left limits: 0,0
- 2.2. Upper right limits: 17,11
- 2.3. Architectural units
- 2.4. Grid: 1/2"
- 2.5. Snap: 1/2"
- 2.6. Draw a border 1/4" in from the limits on all sides (16 1/2" x 10 1/2").
- 2.7. Save the drawing as *MyRuler* to the C:\Steps\Lesson09 folder.

Layer Names	Color	Linetype
Border	magenta	continuous
Gradient	cyan	continuous
Ruler	red	continuous
Text	yellow	continuous
Cl	blue	center

3. Using the *MyBase3* template created in Lesson 1 (or the *Base3* template in the Lesson01 folder), create the next three drawings. Save the drawings to the C:\Steps\Lesson07 folder using the name indicated in the title block of each. All drawings use the layers indicated in the *Layers 1* drawing. (Hint: Change the snap setting as needed.)

Layer Name	Color	Linetype
0	7 (white)	CONTINUOUS
BORDER	5 (blue)	CONTINUOUS
CENTERLINE	6 (magenta)	CENTER
HIDDENLINE	4 (cyan)	HIDDEN
OBJ	1 (red)	CONTINUOUS
TEXT	2 (yellow)	CONTINUOUS

One Step at a Time		
Layers 1		
[Your Name]	Autocad Level 1	
[Your Instructor]	[Class Code]	
NTS	[Date]	Shr. 1 of 1

One Step at a Time		
Block Guide		
[Your Name]	Autocad Level 1	
[Your Instructor]	[Class Code]	
NTS	[Date]	Shr. 1 of 1

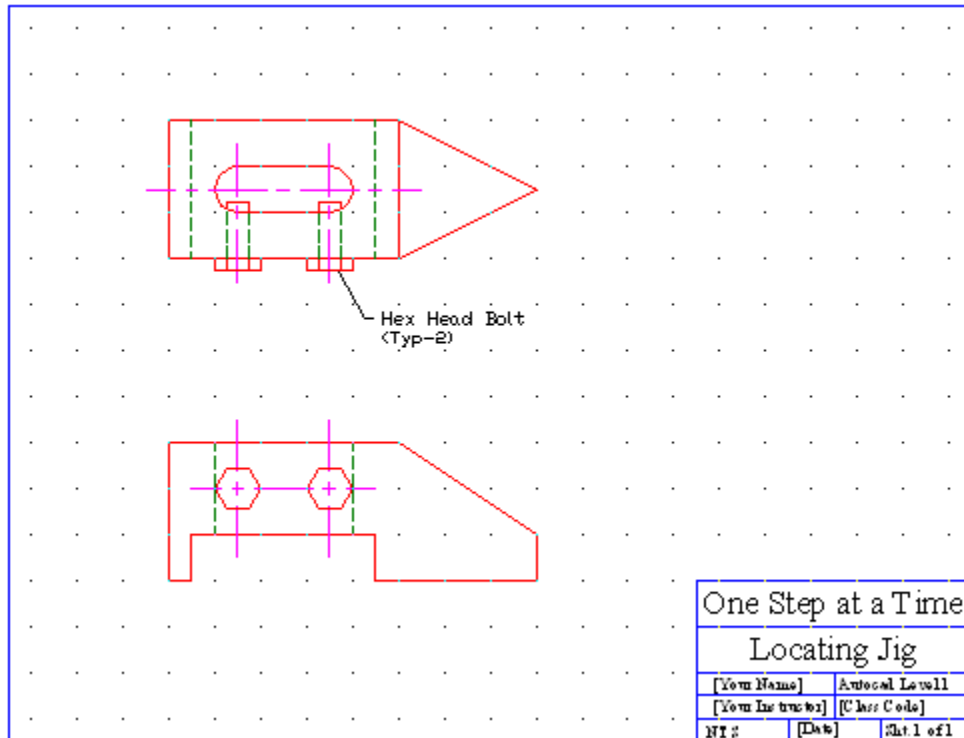

4. Create this drawing. The grid is 2". Use specific layers for each type of object being drawn.

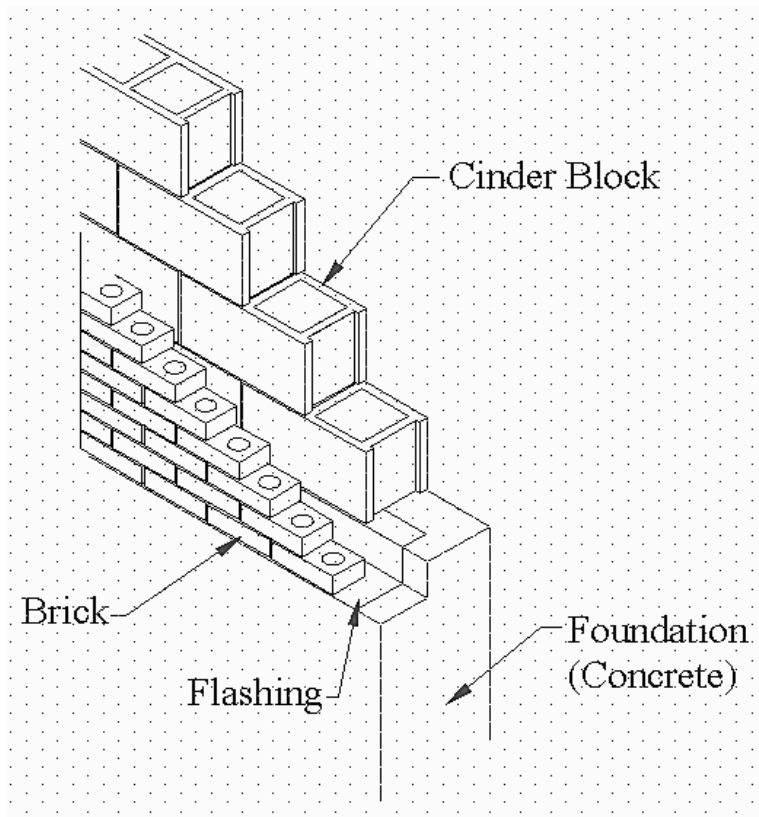

5. Using what you know, create the remaining drawings. The grid on each, when shown, is  $\frac{1}{4}$ ".

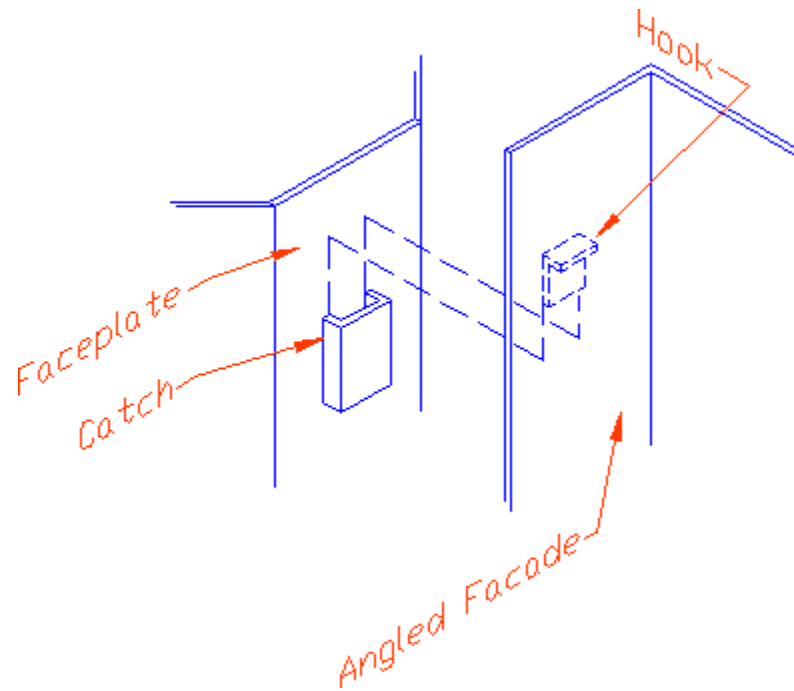
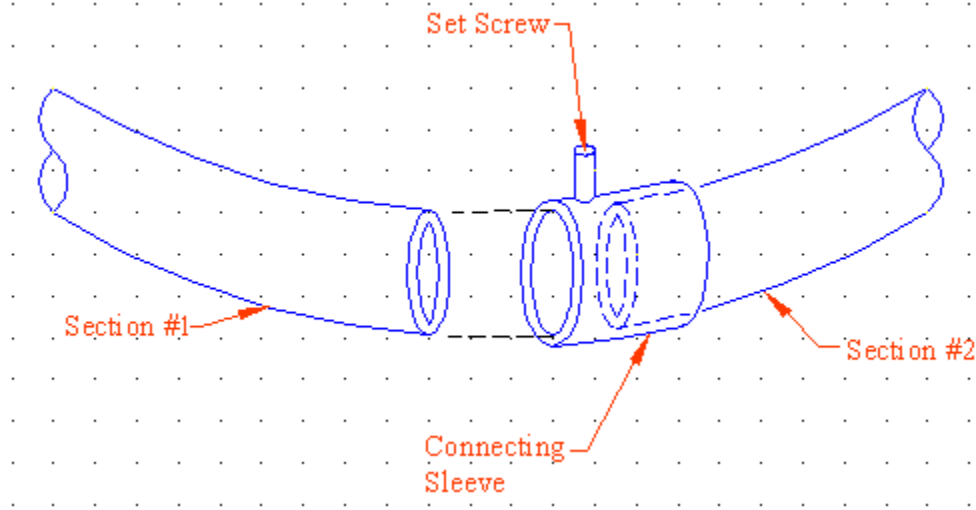

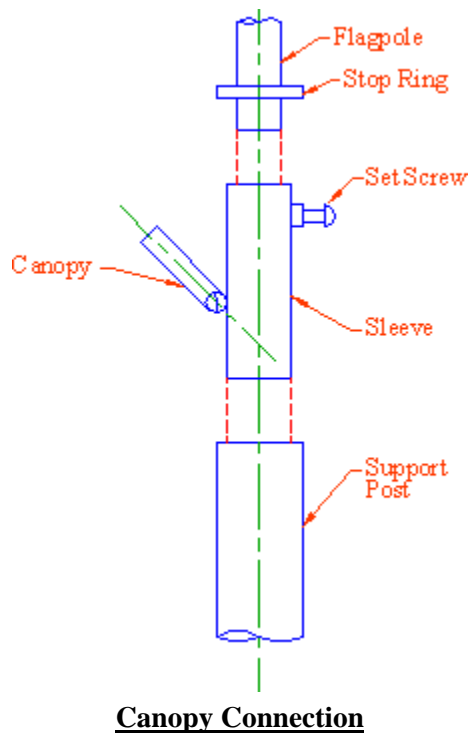
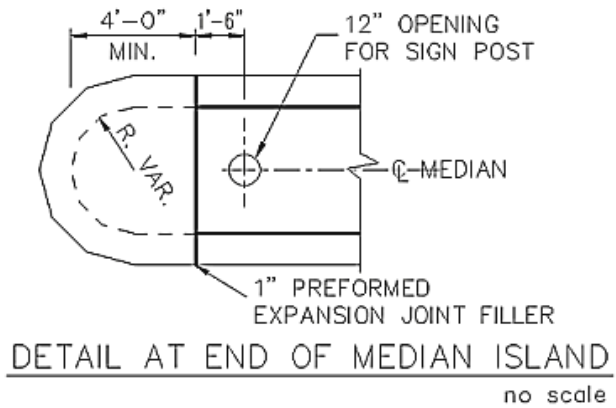

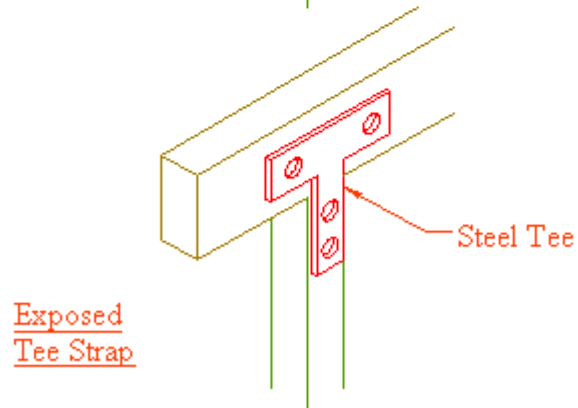
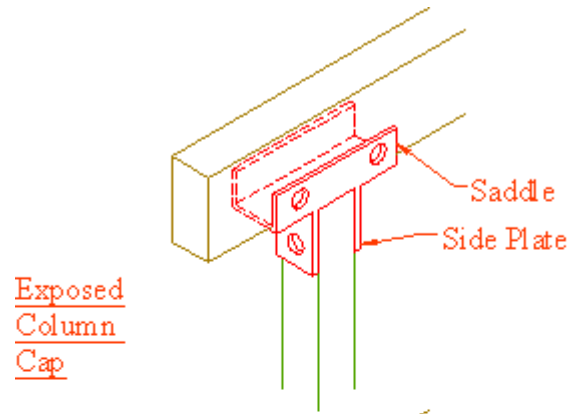

## Beam & Column Connections

Please write your answers on a separate sheet of paper.

1. (T or F) As a rule, the user should not combine the simple color and linetype command approach with the layer approach.
2. (T or F) Layer settings override color and linetype settings.

Identify these layer symbols:

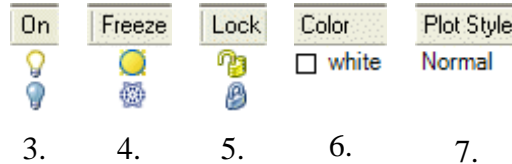

8. You must make a layer \_\_\_\_\_ before you can use it.

To set a layer current, select it in the \_\_\_\_ (9) \_\_\_\_ box on the \_\_\_\_ (10) \_\_\_\_ control panel.

Identify these buttons:



14. Use the \_\_\_\_\_ to copy layer definitions from one drawing to another.
15. A layer refers to
  - a) the color of an object
  - b) the linetype of an object
  - c) a set of predefined colors, linetypes, and other properties
16. The Layer Properties Manager can be called by typing
  - a) layer
  - b) the two-letter hotkey LA
  - c) Help
17. If a layer is frozen it means that
  - a) you can't see the layer but it will regenerate anyway
  - b) you can't see the layer and it will not regenerate
18. (T or F) You need to be in the Layer Properties Manager to make a layer current. You can also use the Layer control box to manipulate the visibility as well as other attributes of a layer.
19. (T or F) You can pick the Make Object's Layer Current button and then pick an object in the drawing to make that object's layer current.
20. (T or F) The user can type ADCenter or ADC to open the AutoCAD Design Center. You may also pick the Design Center button on the Standard Annotation toolbar.
21. (T or F) The ADC can import layers, blocks, dimstyles, text styles, and linetypes from other drawings.

22. Open the Properties Palette by
  - a) typing Properties or Props at the command prompt
  - b) picking the Properties button on the Standard Annotation toolbar
  - c) picking Properties from the Tools pull down menu
  - d) all of the above
23. Use the \_\_\_\_\_ to translate existing layers to meet a set standard.
24. Use the \_\_\_\_\_ command to turn off all except the user-selected layer.
25. The \_\_\_\_\_ command will remove a layer and everything that resides on it from your drawing.
26. (T or F) When you lock a layer, AutoCAD will automatically fade objects on that layer.
27. (T or F) You can control objects that are printed/plotted through the Layer Manager.
28. Save your current layer settings with the \_\_\_\_\_.
29. (T or F) You can't use the Layer States Manager to share layer settings between drawings.
30. Control the amount of locked-layer fading with the \_\_\_\_\_ system variable.

### Answers

- |                                 |                          |
|---------------------------------|--------------------------|
| 1. T                            | 16. a & b                |
| 2. F                            | 17. b                    |
| 3. On/Off Toggle                | 18. F                    |
| 4. Frozen/Thawed Toggle         | 19. T                    |
| 5. Locked/Unlocked Toggle       | 20. T                    |
| 6. Color pick                   | 21. T                    |
| 7. Plot Style pick              | 22. d                    |
| 8. Current                      | 23. Layer Translator     |
| 9. Layer Control                | 24. LayIso               |
| 10. Layers                      | 25. LayDel               |
| 11. Layer Properties Manager    | 26. T                    |
| 12. Make Object's Layer Current | 27. T                    |
| 13. Properties                  | 28. Layer States Manager |
| 14. ADC                         | 29. F                    |
| 15. c                           | 30. LayLockFadeCTL       |