

AutoCAD 2008: One Step at a Time

Lesson 6: Object Properties – Color at Last (and More!)

08R6

Exercises

1. Create the remote control drawing at right using the following setup. Save the drawing as *MyRemote* in the C:\Steps\Lesson06 folder.

Object	Color
Button	62
Text	yellow
Toggle	blue
Up-Down	211

- 1.1. Lower left limits: 0,0
- 1.2. Upper right limits: 6,10
- 1.3. Architectural units
- 1.4. Grid: 1/4"
- 1.5. Snap: as needed
- 1.6. Font: Times New Roman
- 1.7. Text Height: 1/8

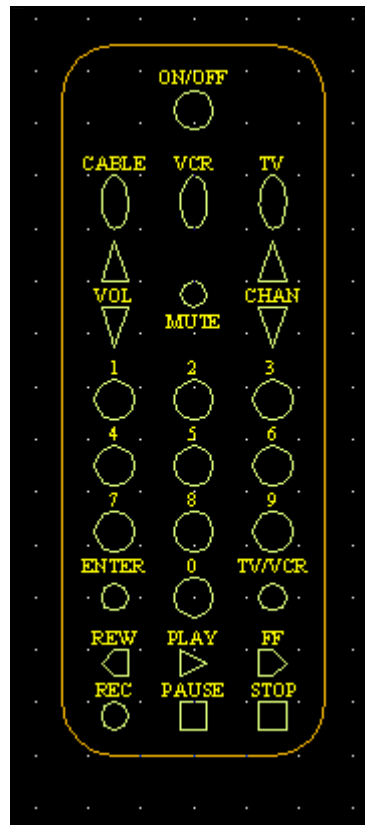

2. Using the *MyBase3* template created in Lesson 1 (or the *Base3* template in the Lesson01 folder), create the next three drawings. Save the drawings to the C:\Steps\Lesson06 folder using the name indicated in the title block of each. Use the colors shown or select your own. (Hint: Change the snap setting as needed.)

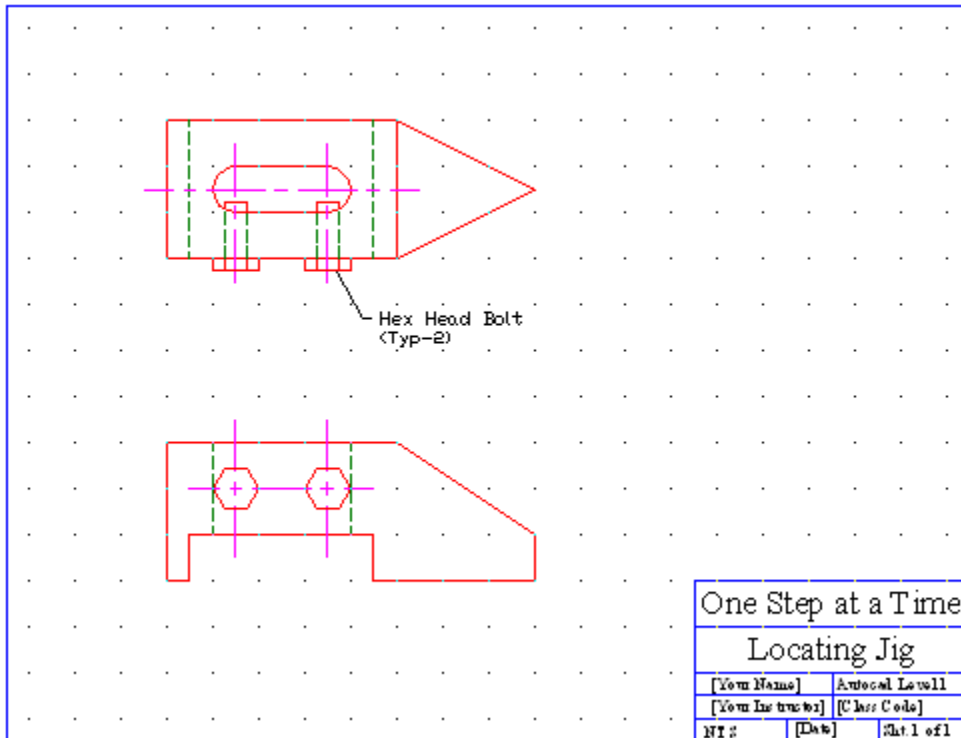
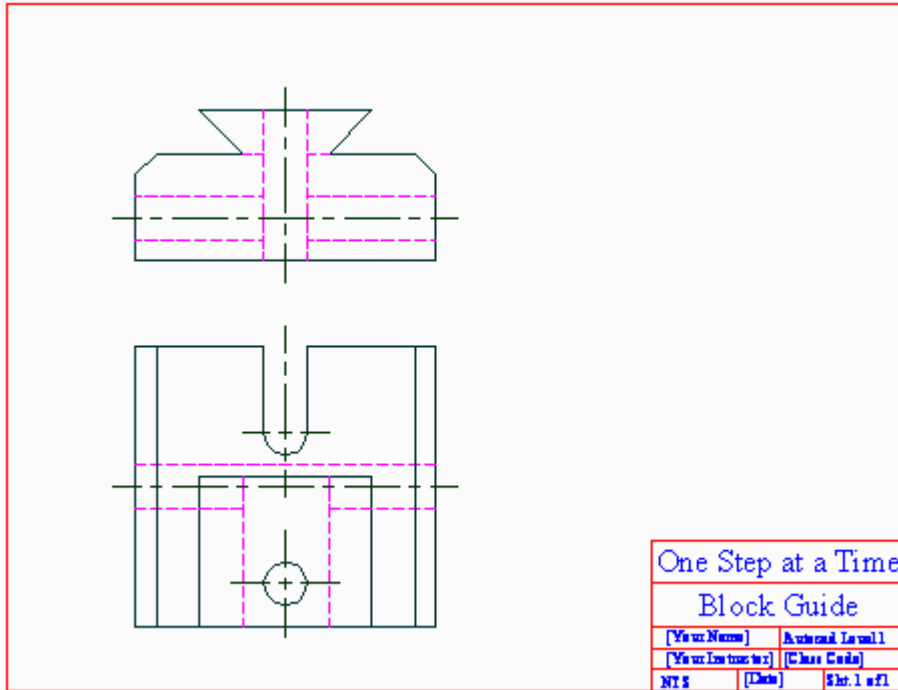

3. Create this drawing. The grid is 2". Use colors for each type of object being drawn.

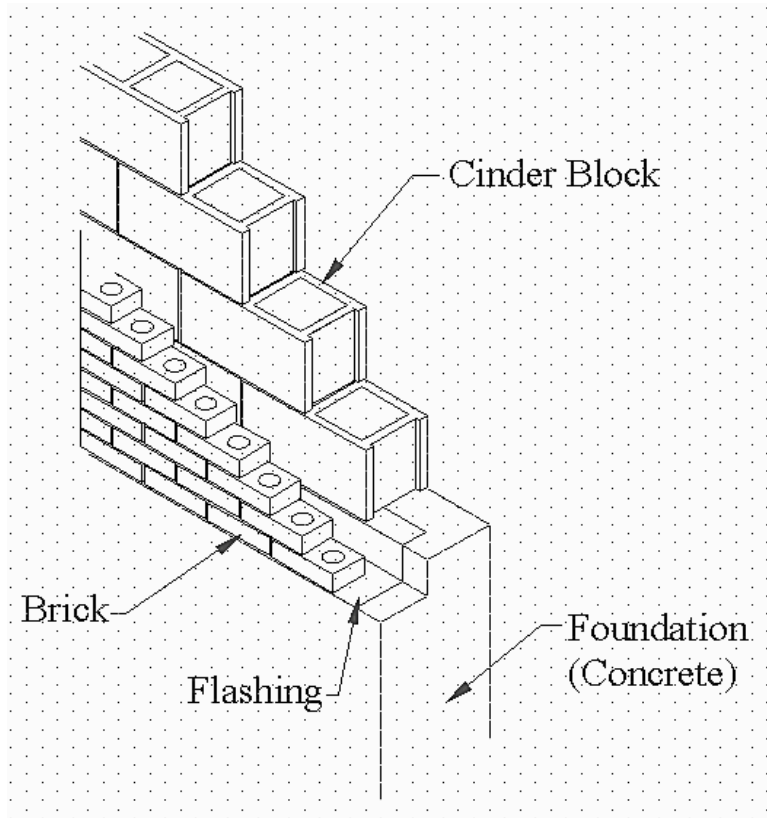

4. Using what you know, create the remaining drawings. The grid on each, when shown, is 1/4".

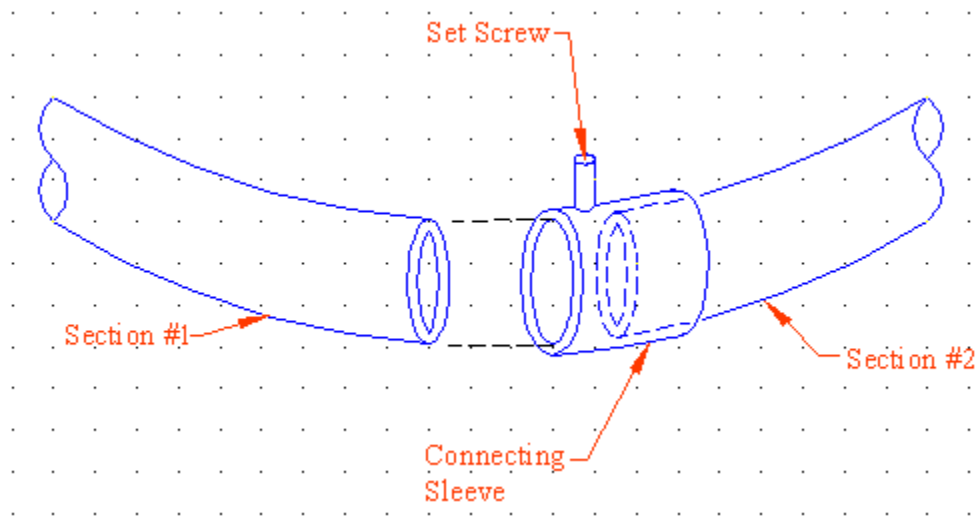

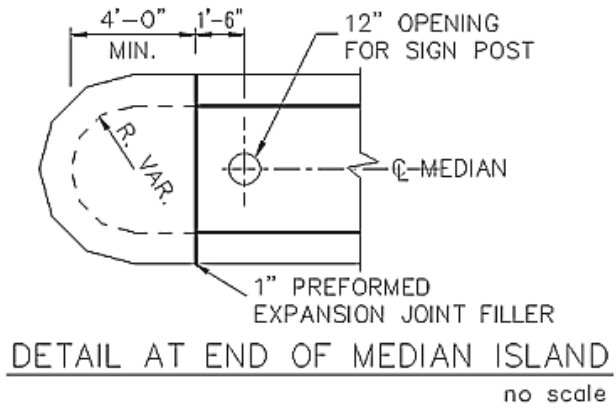
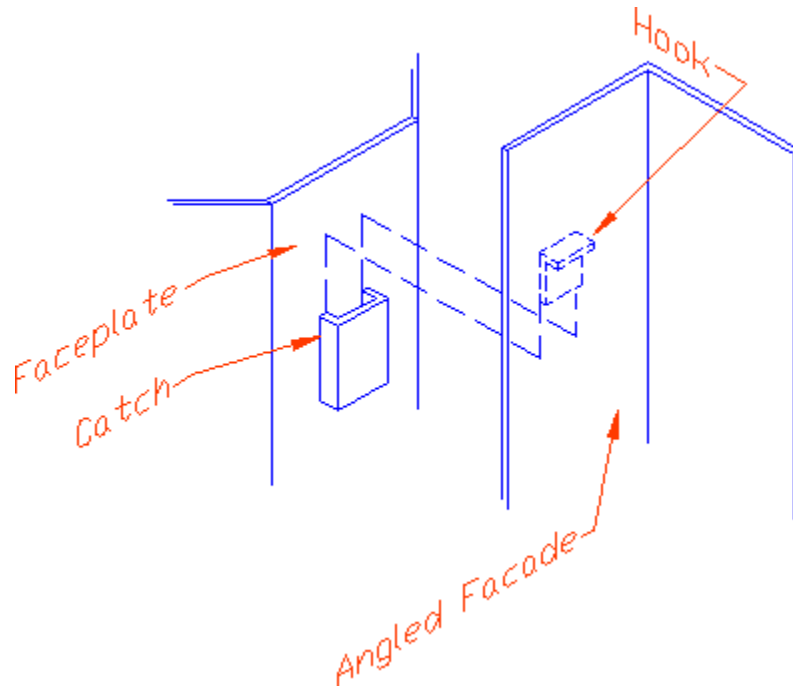

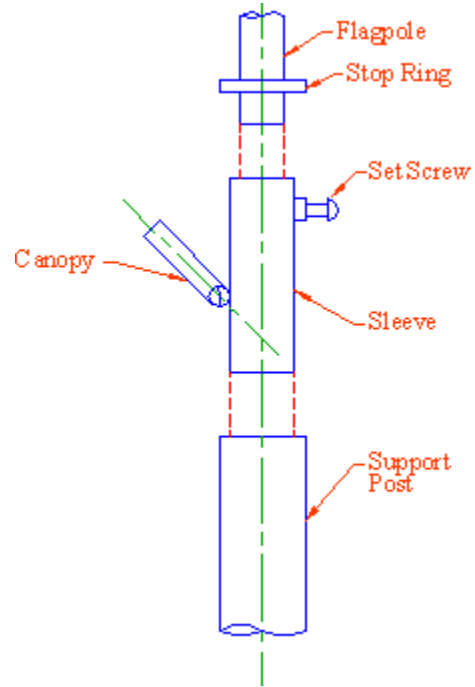

Canopy Connection

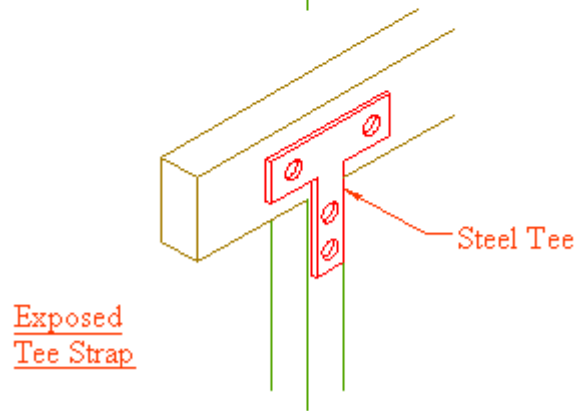
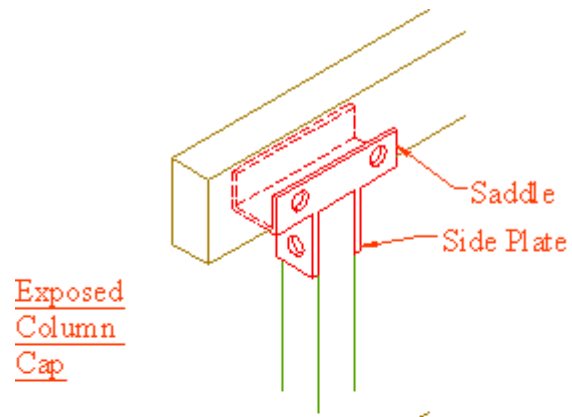

Beam & Column Connections

Please write your answers on a separate sheet of paper.

1. (T or F) As a rule, the user should not combine the simple color and linetype command approach with the layer approach.
2. The color selection drop-down box is located on the _____ control panel.
3. The _____ color selection assigns colors according to the current layer setting.

To reach the Select Color dialog box, pick the (4) option from the Color Control box, or enter (5) at the command prompt.

- 4.
- 5.

List AutoCAD's seven primary colors.

- 6.
- 7.
- 8.
- 9.
- 10.
- 11.
- 12.

To assign a color that is not one of AutoCAD's primary colors, select it from the (13) or enter its number code in the (14) box of the Select Color dialog box.

- 13.
- 14.
15. To match paint colors used by the Pantone company, go to the _____ tab of the Select Color dialog box.
16. To get to the Load or Reload Linetypes dialog box, pick the _____ button on the Linetype Manager.
17. What is the name of the default file in which AutoCAD's linetype definitions are stored?
18. To select more than one linetype at a time to load, hold down the _____ key while selecting the linetypes.
19. To adjust the size of dashes and spaces in dashed lines to the scale of the drawing, set the _____ of the drawing.
20. What will you use to change an object's properties?
21. Open the Properties Palette by
 - a) typing Properties or Props at the command prompt
 - b) picking the Properties button on the Object Properties toolbar
 - c) picking Properties from the Tools pull down menu
 - d) all of the above

22. WYSIWYG means _____.

23. Use the _____ button on the Properties palette to filter objects in a drawing.

Answers

1. T
2. Object Properties
3. Bylayer
4. Other
5. Color
6. White
7. Red
8. Green
9. Blue
10. Yellow
11. Cyan
12. Magenta
13. Select Color dialog box
14. Color
15. Color Books
16. Load
17. Acad.lin
18. Control
19. Annotation scale
20. Properties palette
21. d
22. What You See Is What You Get
23. Quick Select